

1/8" x 1/2" trailing edge stock

1/8" sheet center rib

1" wide strip of .75oz fiberglass cloth used to reinforce wing bottom center section (wrap around leading edge 1/2")

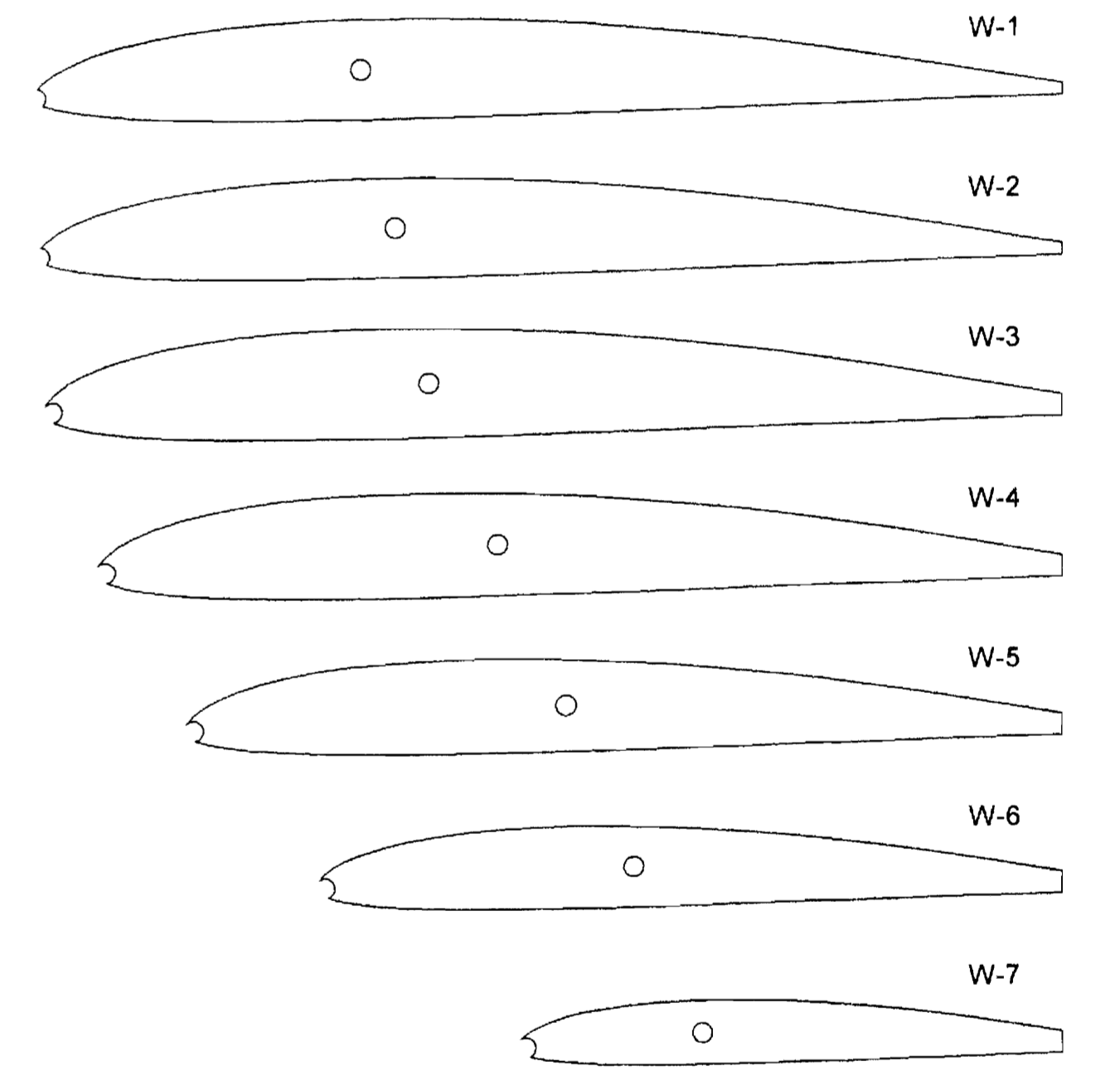

control surface throws:
3/16" up/down
1/4" right/left

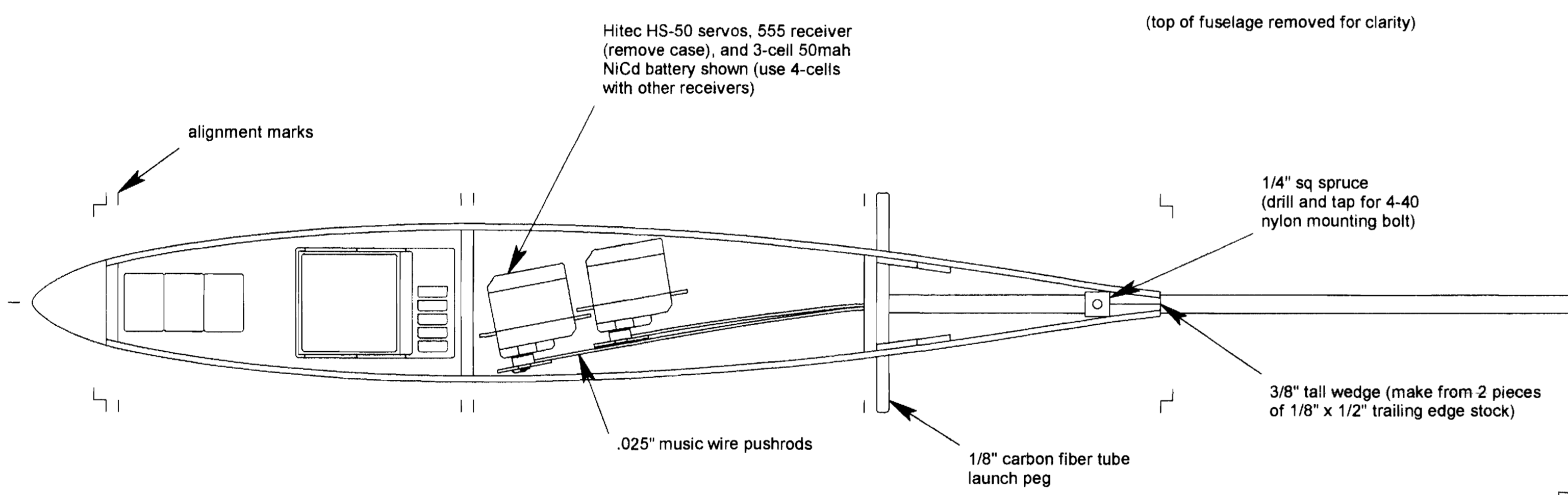
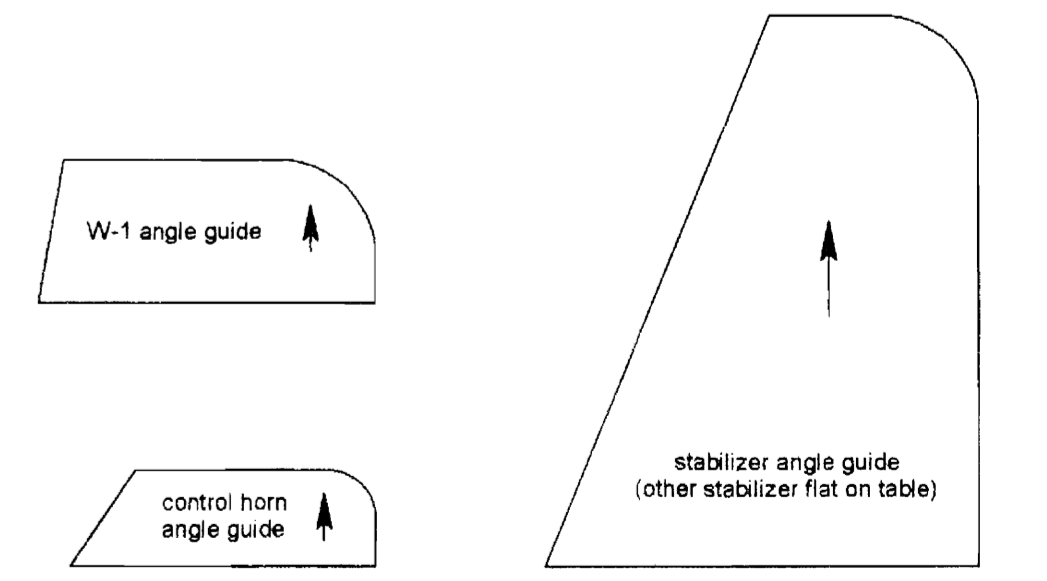

span... 29.5 in
area... 163 sq in
weight... 3.5 oz

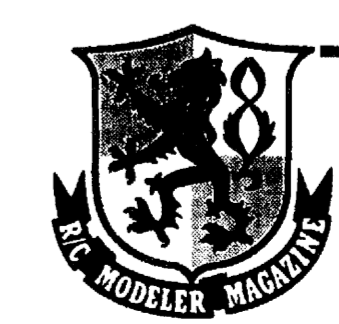
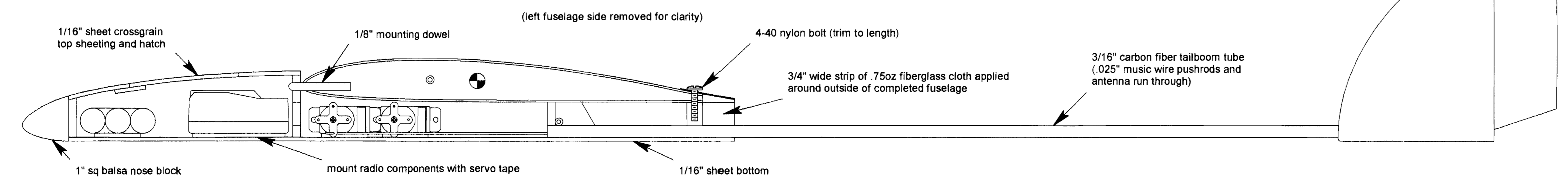
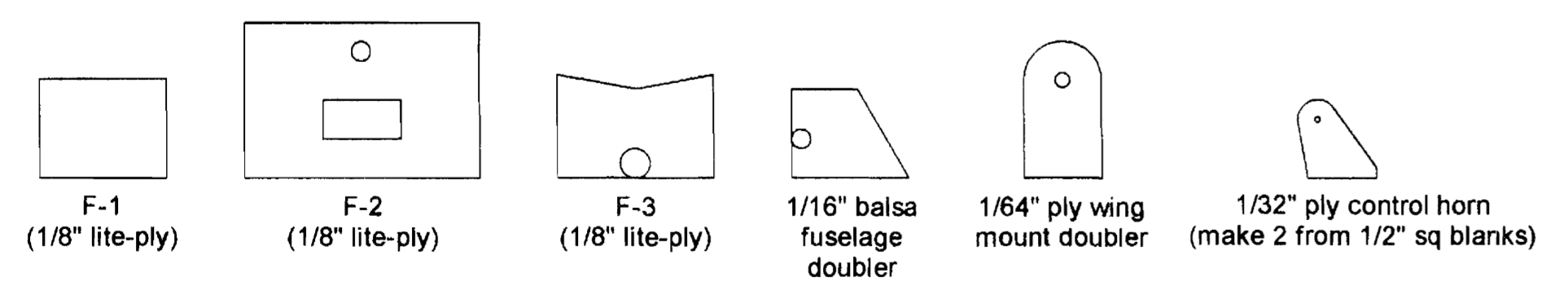
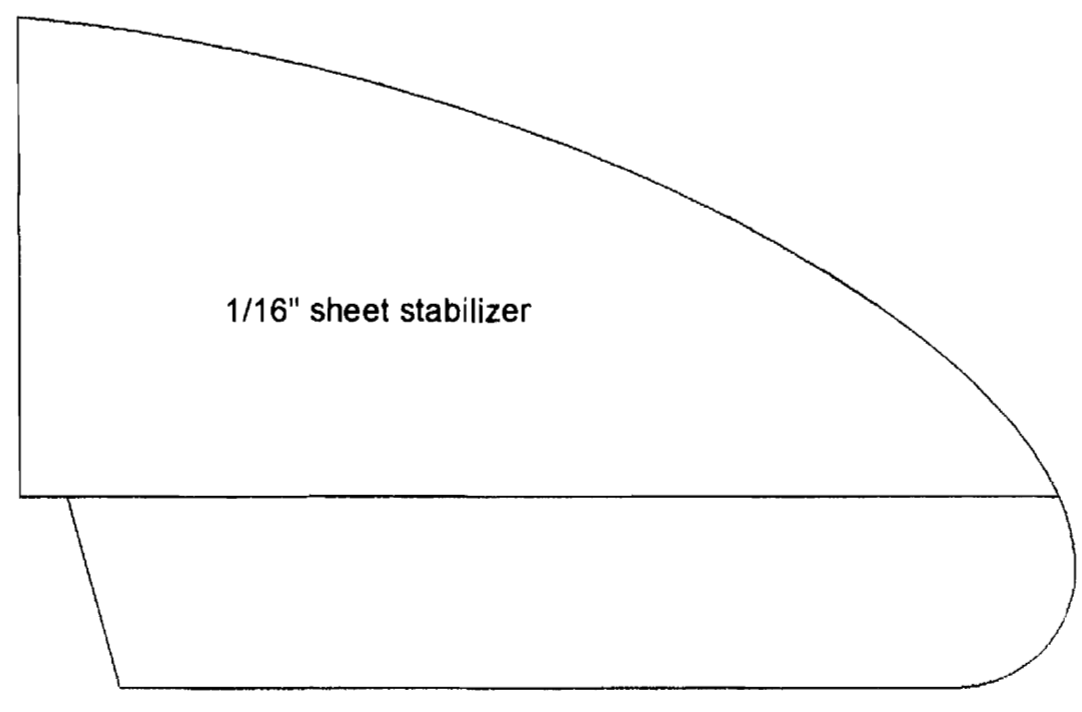
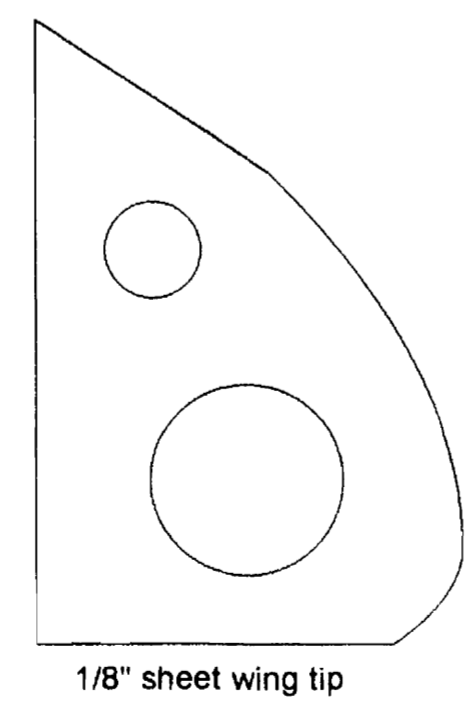
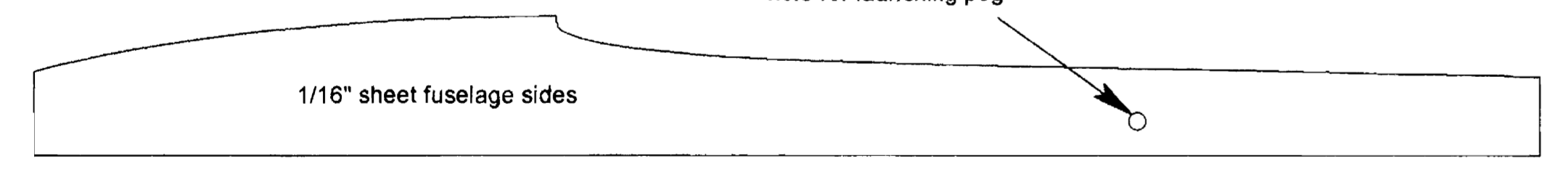

THE BUG

DESIGNED BY: CARL DOWDY

PLANS BY: CARL DOWDY

