

SLICK 360-35
 WING SPAN: 35" LENGTH: 35.2"
 WEIGHT: 16 - 18 oz.
 MOTOR: GForce 2830/9T or equivalent
 ESC: 25 AMP
 BATTERY: 3s 1000-1300 MAH.
 SERVOS: 9 GRAM
DESIGNED BY: DOUG GREEN

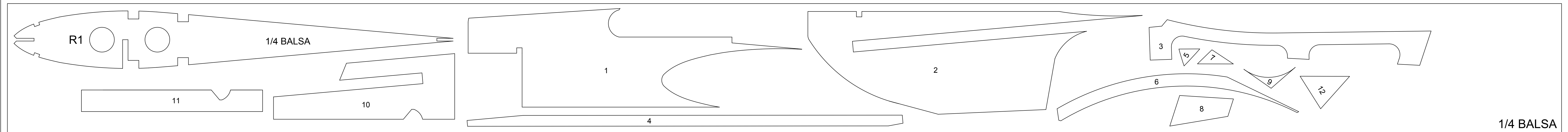
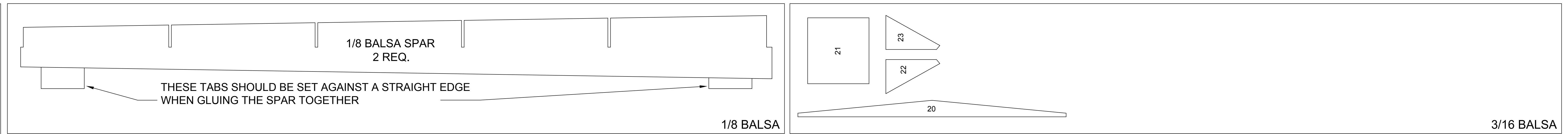
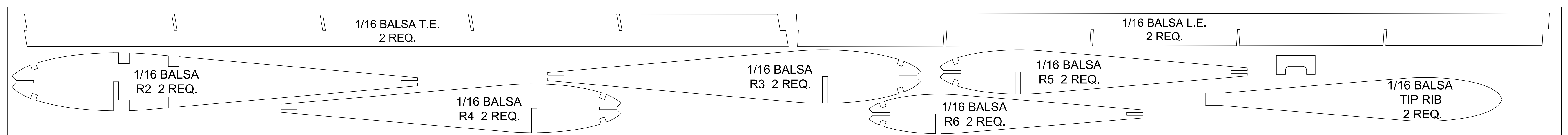

TO VERIFY SCALE BORDER SHOULD MEASURE 34.00 x 46.00