

P-51D MUSTANG

TYPE S

MASSTAB	SCALE	1:9,6	1-1/4"=1"
LÄNGE	LENGTH	1023mm	40-5/16"
SPANNWEITE	WING SPAN	1175mm	46-1/4"
FLÄCHENINHALT	WING AREA	24dm ²	372 SQ. IN.
GEWICHT	WEIGHT	2,0-2,2kg	4,5-5,0 LB.
MOTOR	ENGINE	3-4ccm	19-25 → 40
R/C-ANLAGE	R/C CONTROL	3-4 CH	→ 6



丸鷹 R/C モデル

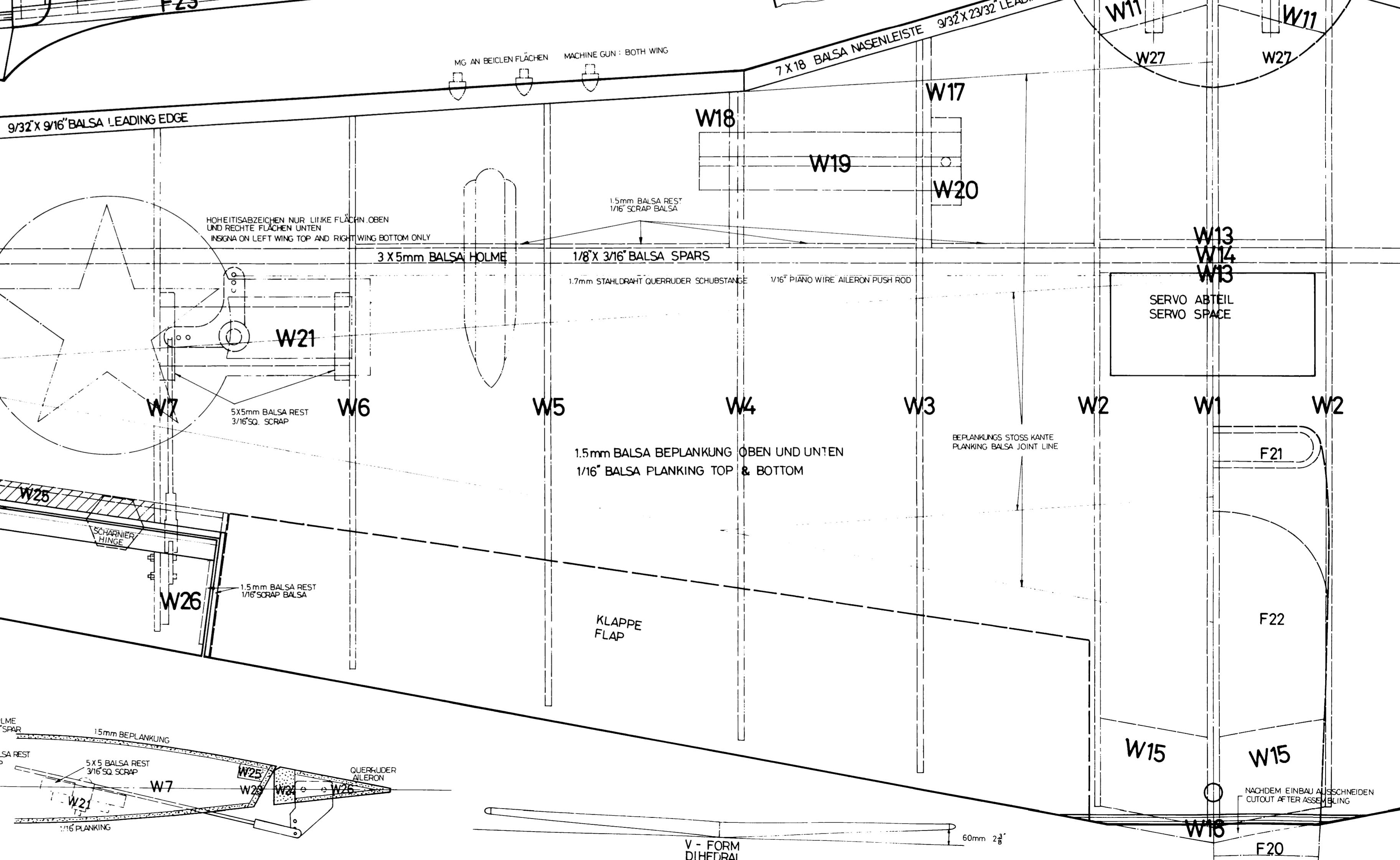
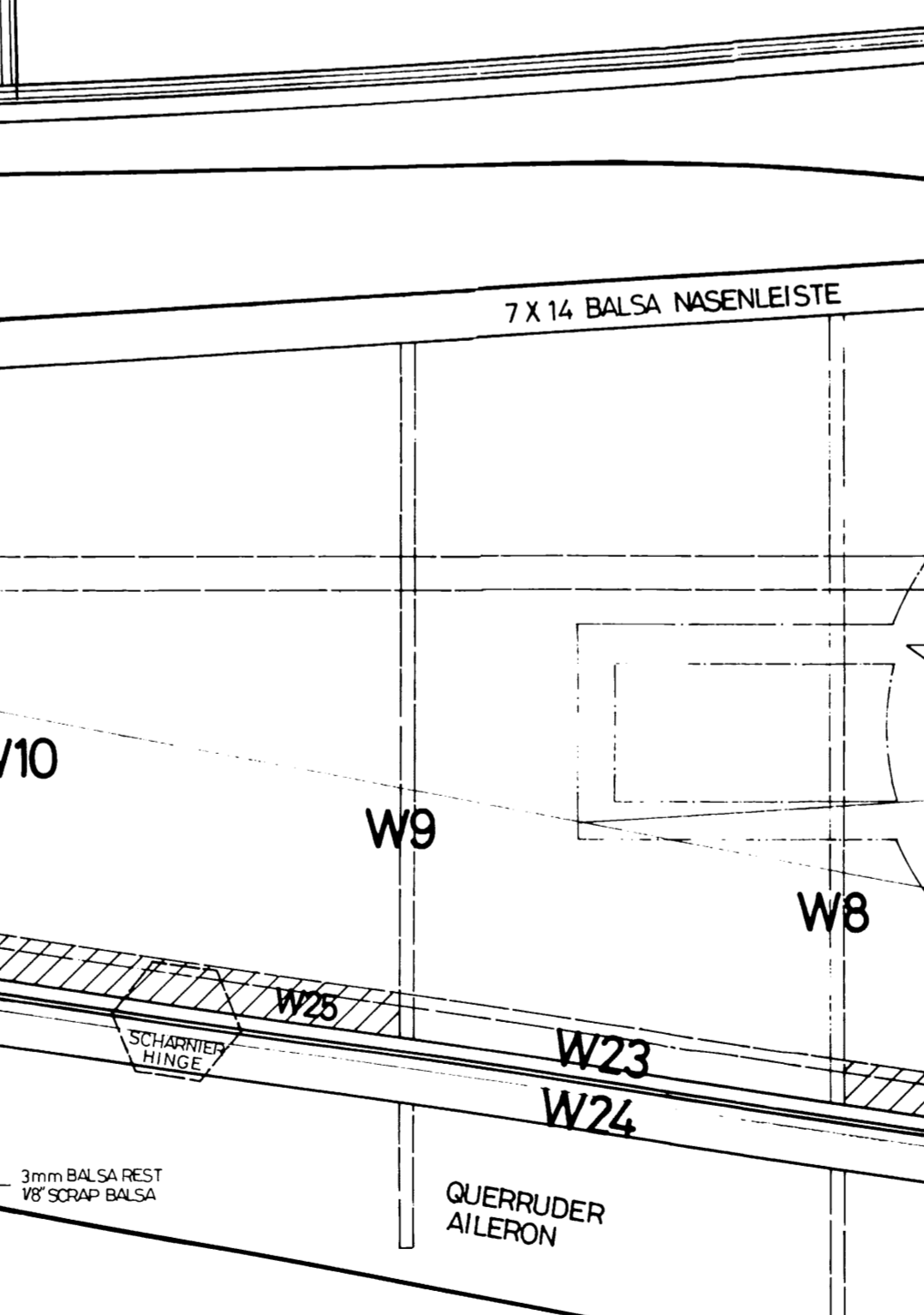
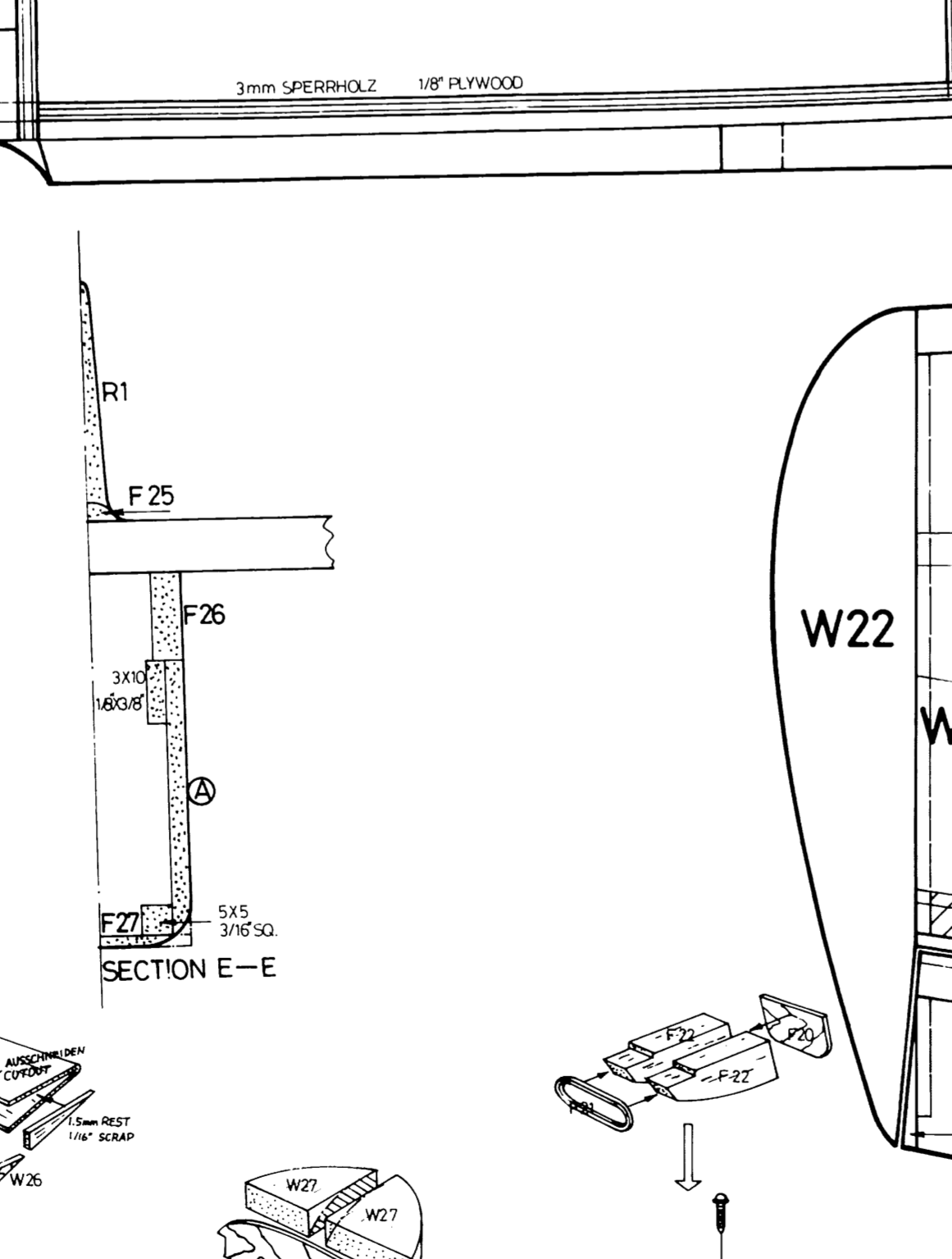
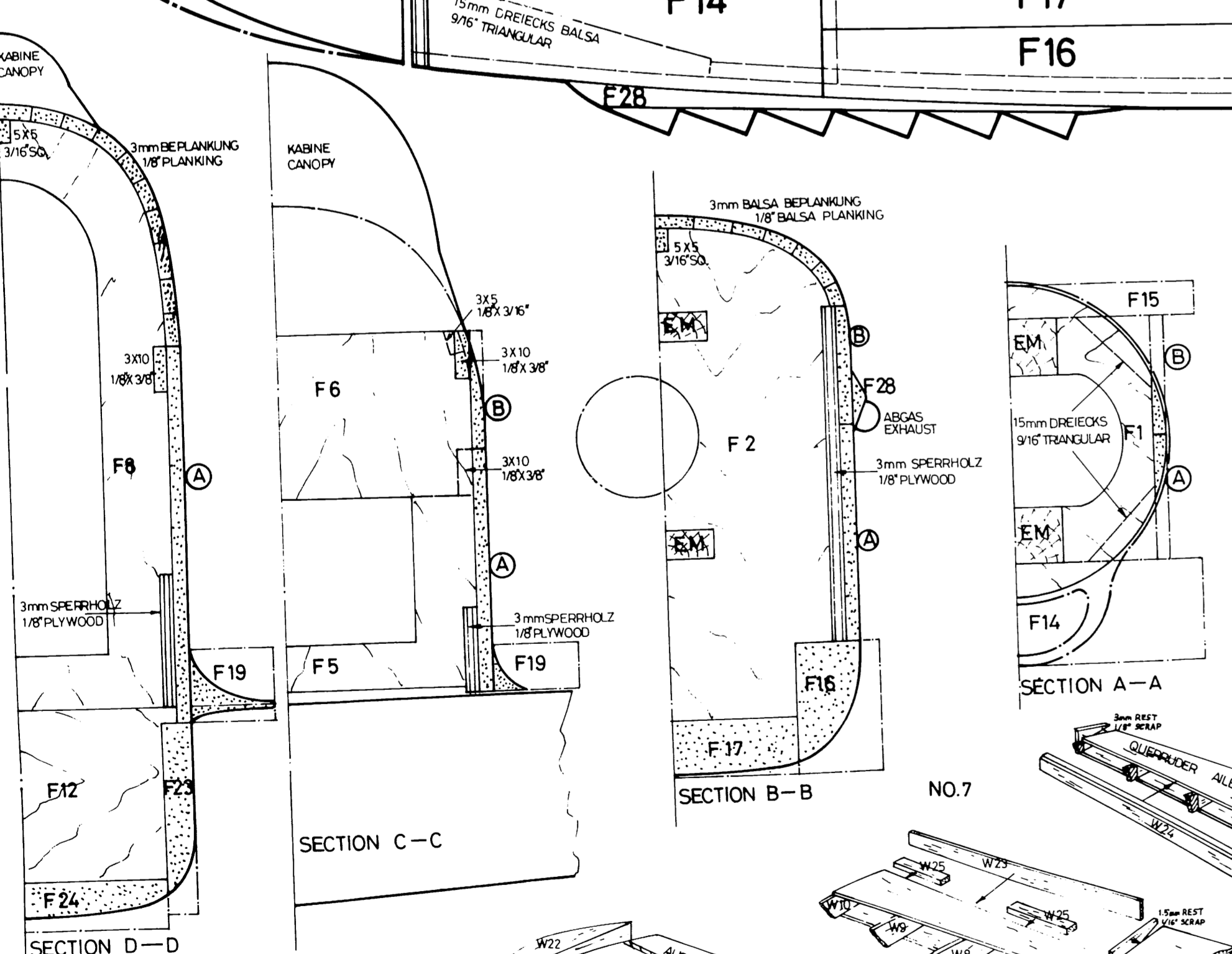
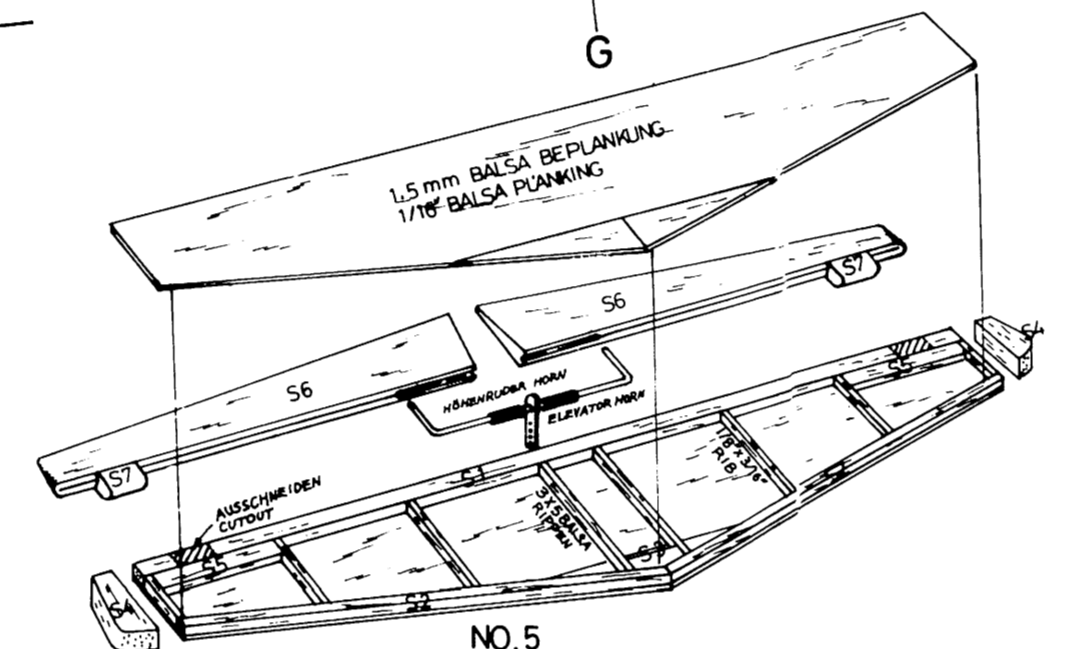
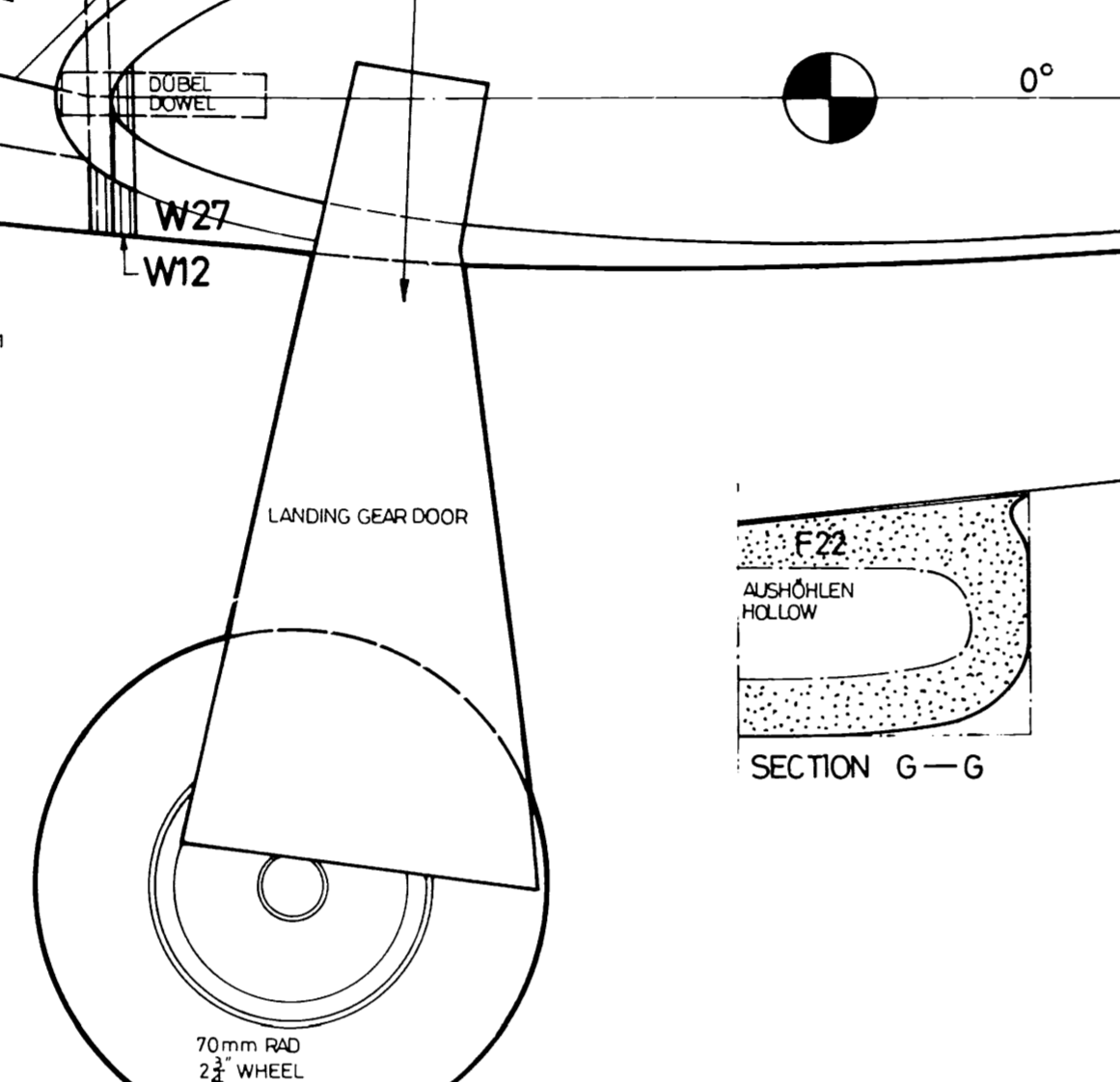
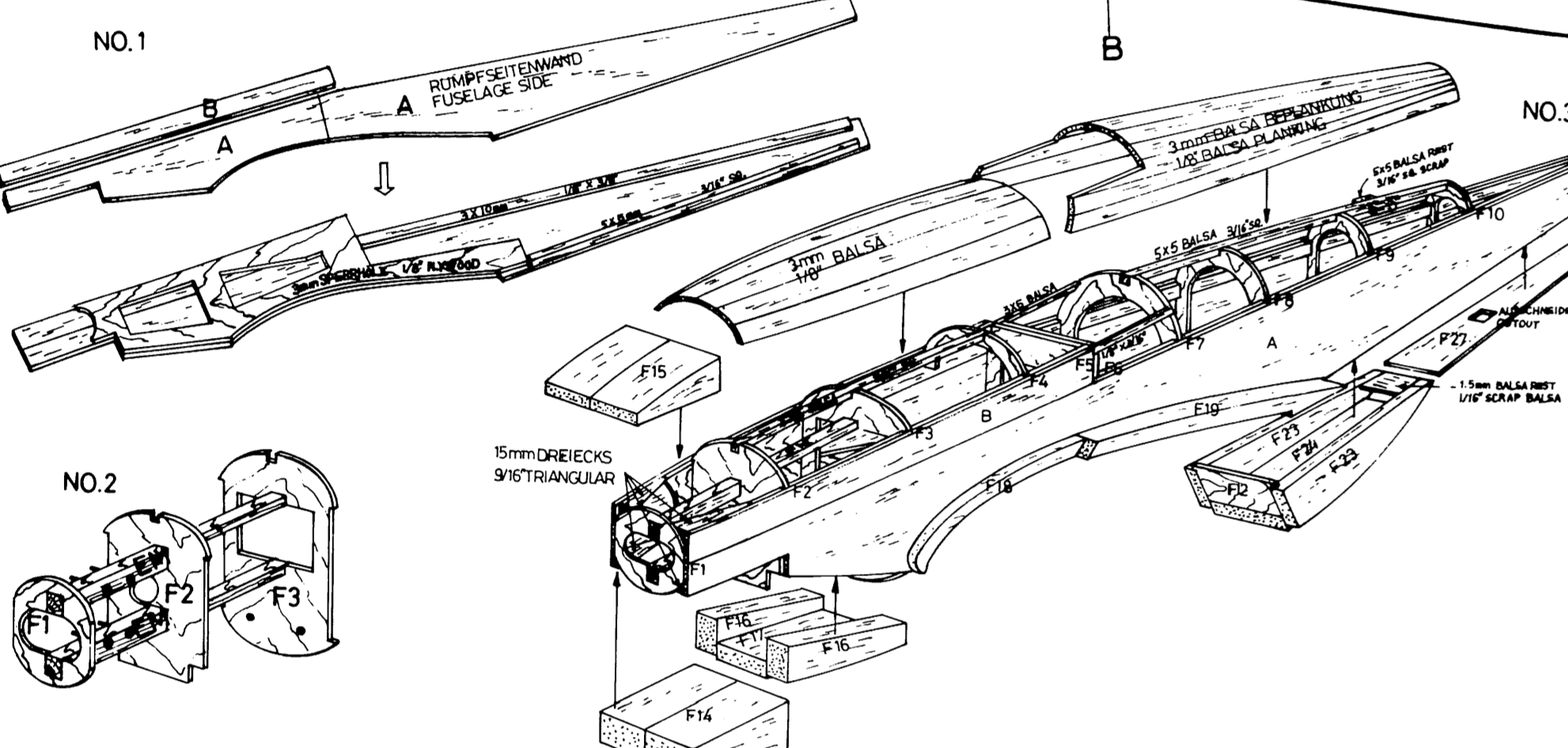
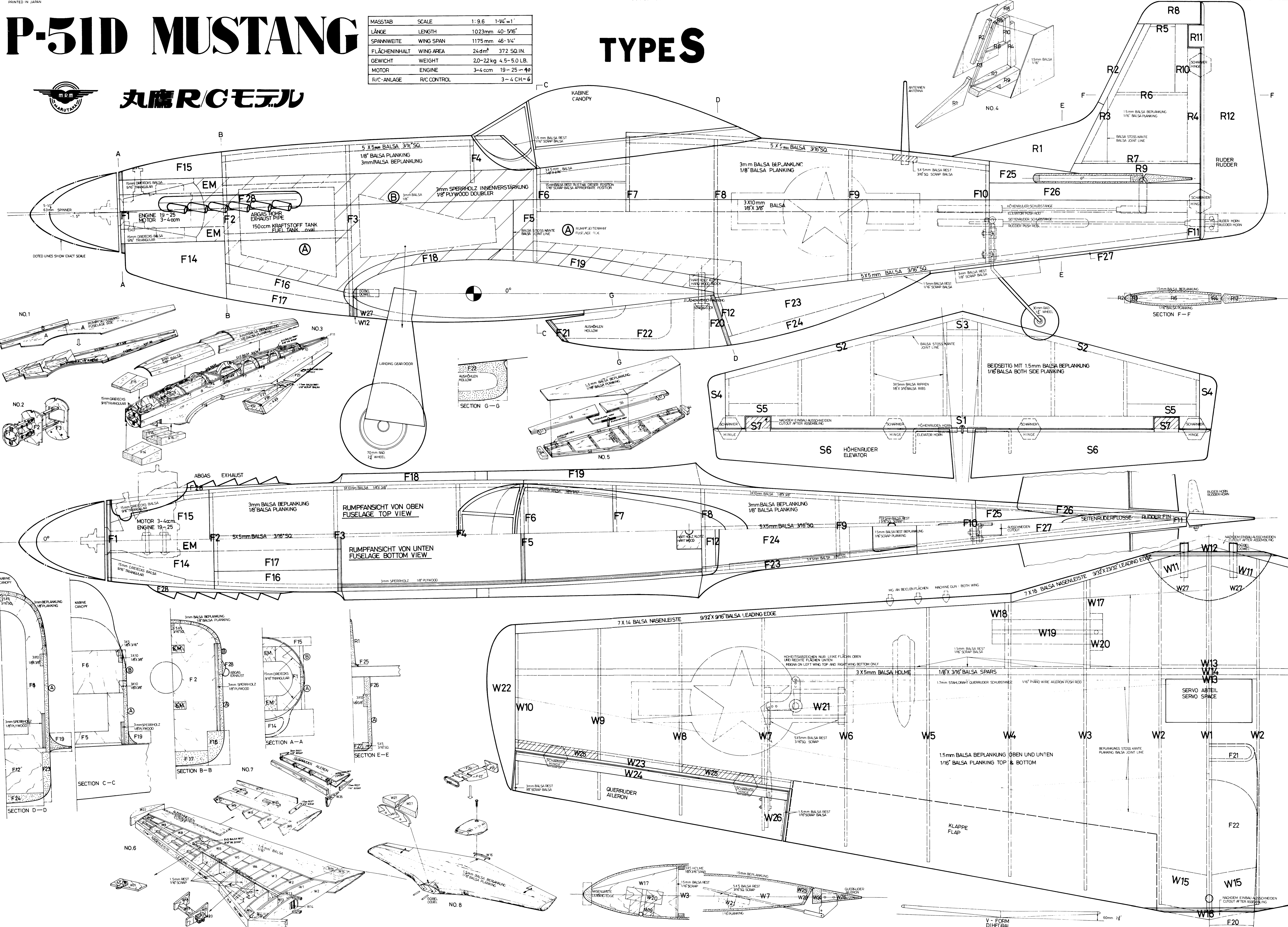

3MM PLYWOOD

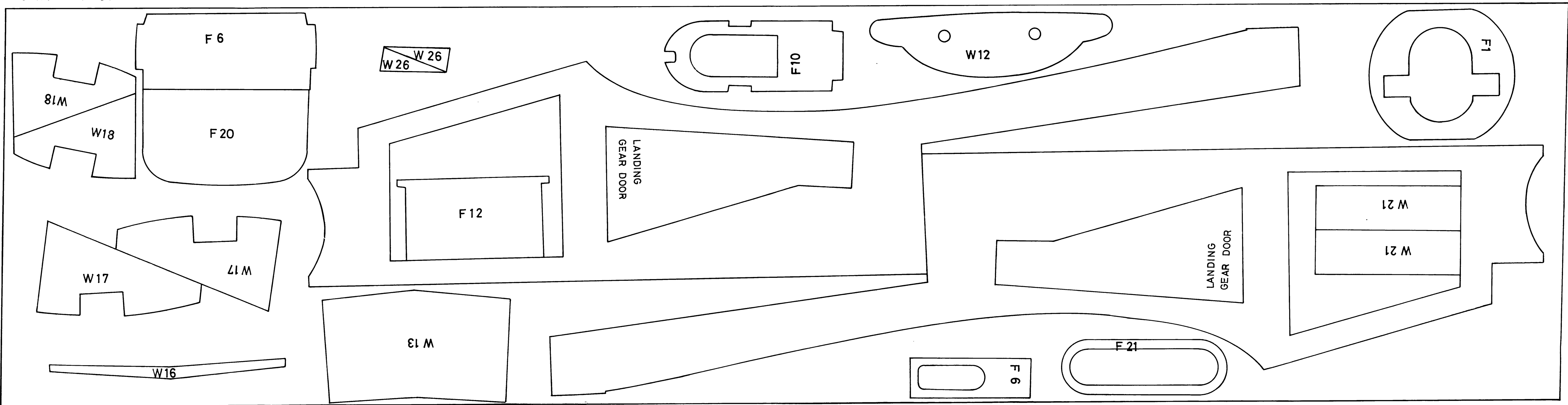

3MM PLYWOOD

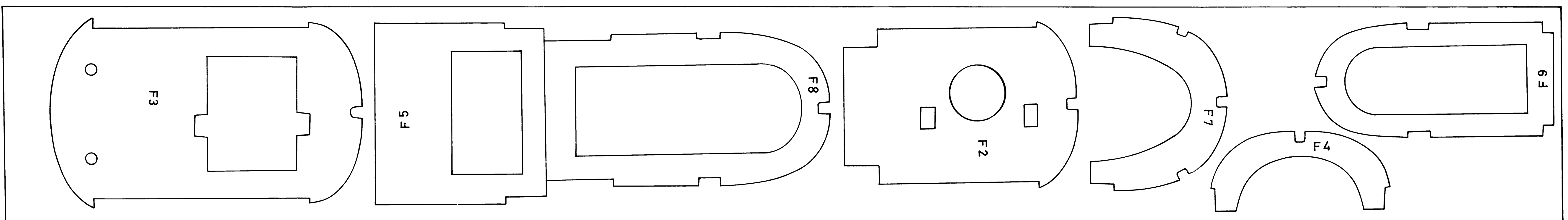

2MM Balsa

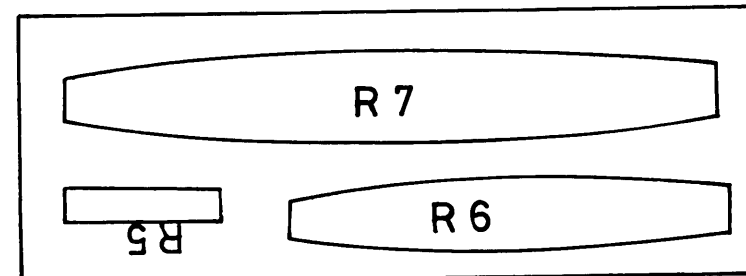
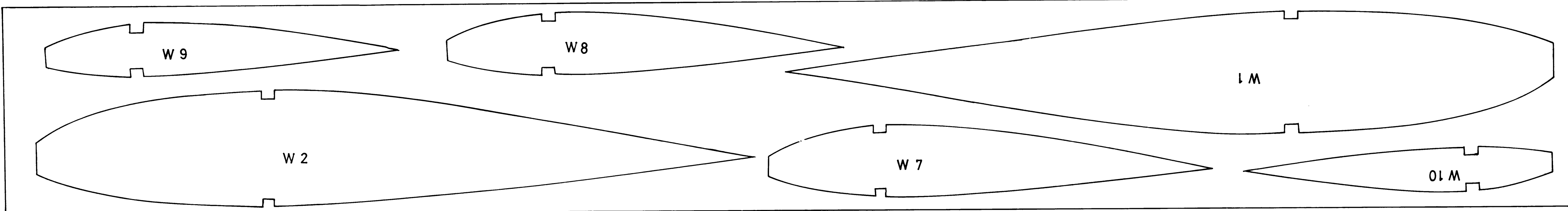

2MM Balsa

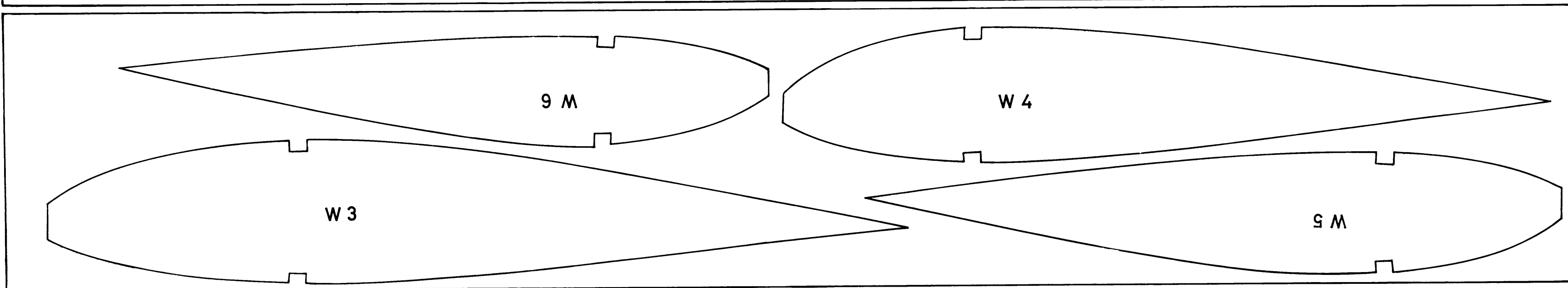

2MM Balsa

BEFORE STARTING BUILDING
 FOR BETTER FINISH AND FLIGHT PERFORMANCE, TAKE TIME IN READING BUILDING INSTRUCTION AND REFERING TO THE PLANS, AND ASSEMBLE IN GOOD ORDER AND CORRECTLY AND CAREFULLY.
 CUT OFF EACH PART WITH CUTTER OR RAZOR BLADE AVOIDING DAMAGE, PARTICULARLY ON THE JOINTING CUT AND SLOT.
 IF NECESSARY THE PARTS FOR EASIER FITTING. WHEN CEMENTING USE THREAD, RUBBER BAND, PINS, CLOTH CLIPS ETC. UNTIL CEMENT SETS.
 FOR FORMING AND WORKING, CUTTER, Balsa PLANE AND/OR FILE ARE TO BE USED. WOOD TIP WRAPPED WITH SAND PAPER CAN ALSO BE USED AS A FILE.

P-51D MUSTANG

START ASSEMBLING AFTER REFERING THE DIE CUT Balsa AND PLYWOOD PARTS TO THE NUMBER ON THE PLANS.