

NOTES:

THIS DRAWING IS INTENDED TO SHOW INTERNAL DETAILS THAT WOULD ENHANCE THE FIDELITY TO SCALE OF THE MODEL. IN SOME CASES IT WILL NOT BE PRACTICAL TO ADD ALL THE DETAIL INDICATED IF RUBBER POWER IS THE MOTIVE POWER. THE SEAT AND CONTROL COLUMN WILL HAVE TO BE OMITTED IF RUBBER POWER IS GOING TO BE USED.

IF THE MODEL IS TO BE BUILT FOR STATIC SHOW OR RADIO CONTROL, ALL DETAILS MAY BE ADDED. NOT ALL MATERIAL FOR THE COCKPIT DETAIL IS SUPPLIED.

MODEL CONSTRUCTION DETAIL IN THE COCKPIT AREA IS HEAVILY INDICATIVE OF THE FULL SIZE AIRCRAFT ALTHOUGH NOT AN EXACT REPLICATION (SURROUNDING STRUCTURE) OF FULL SIZE.

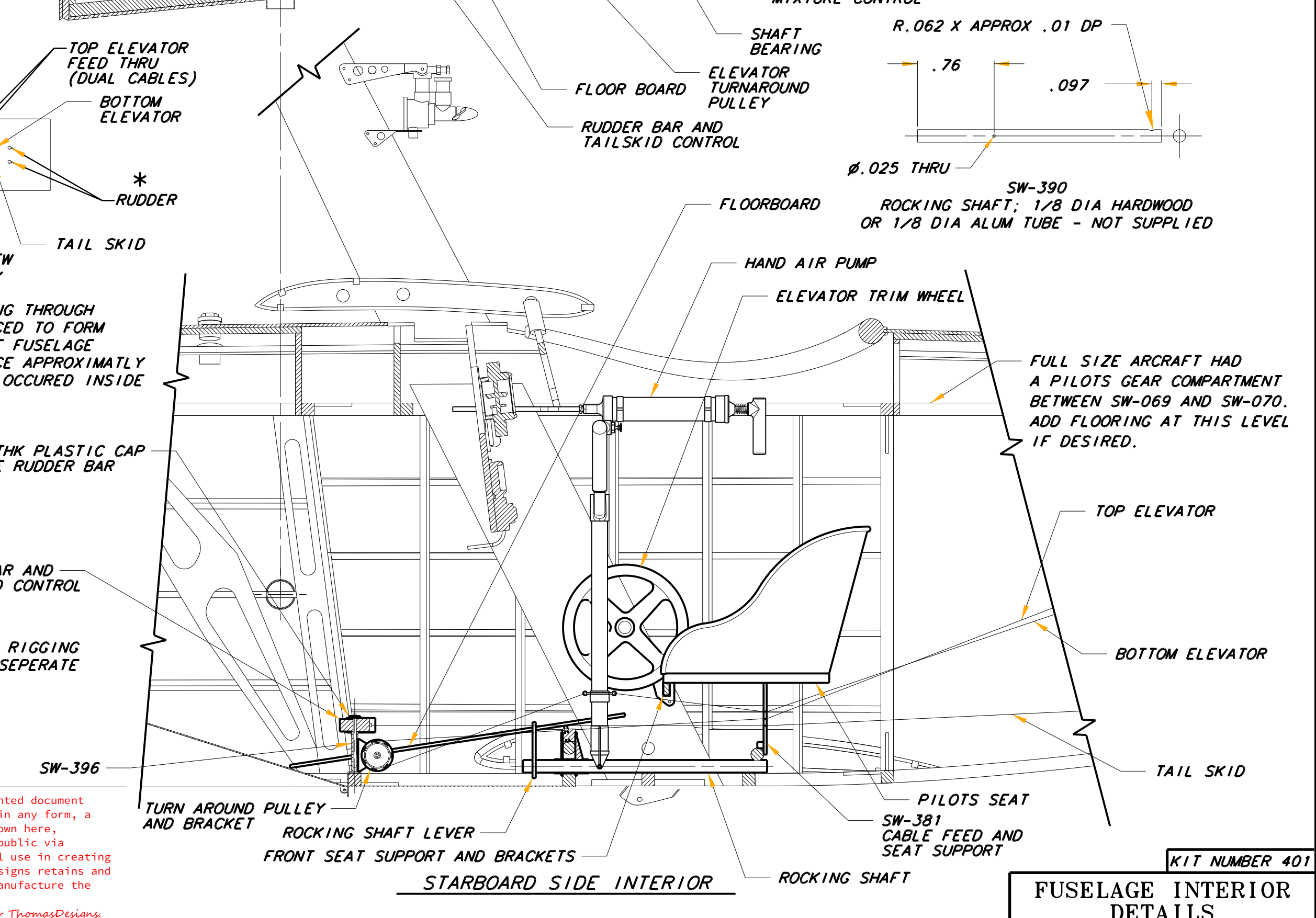
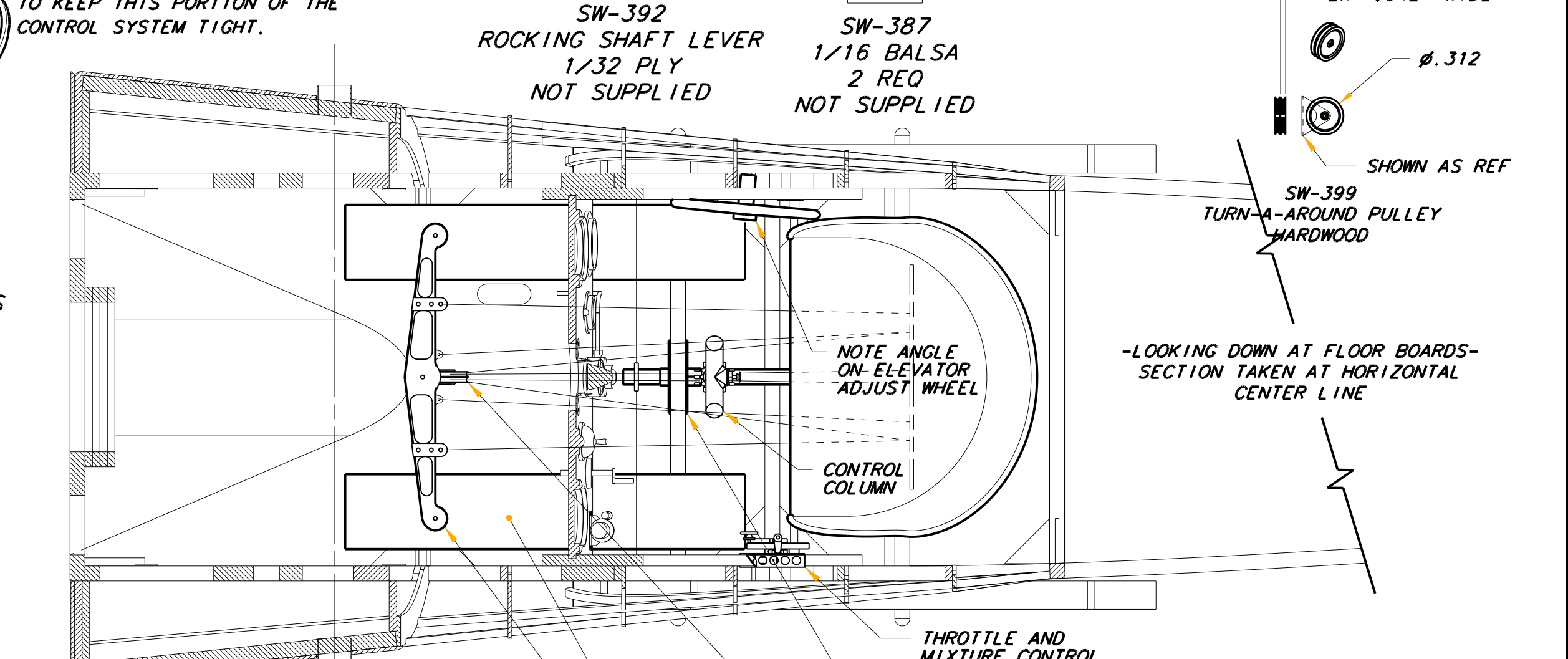
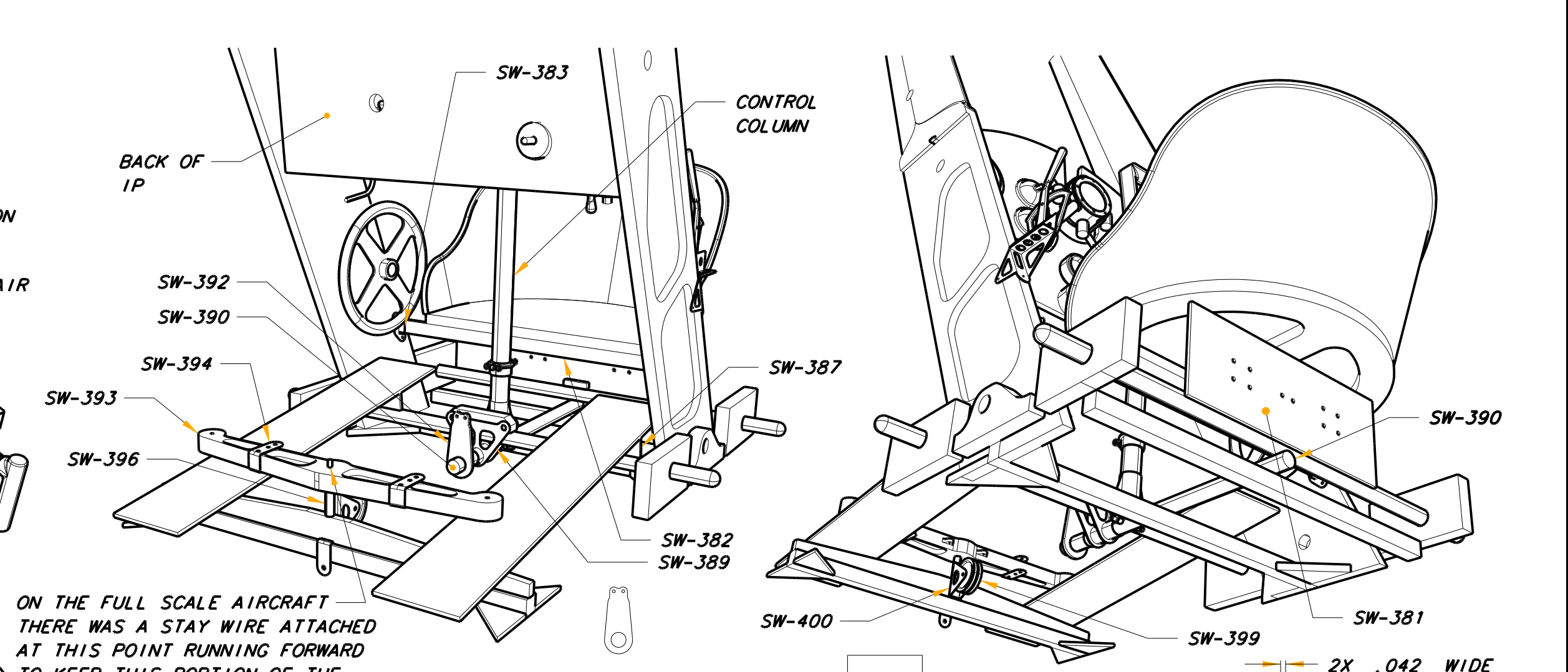
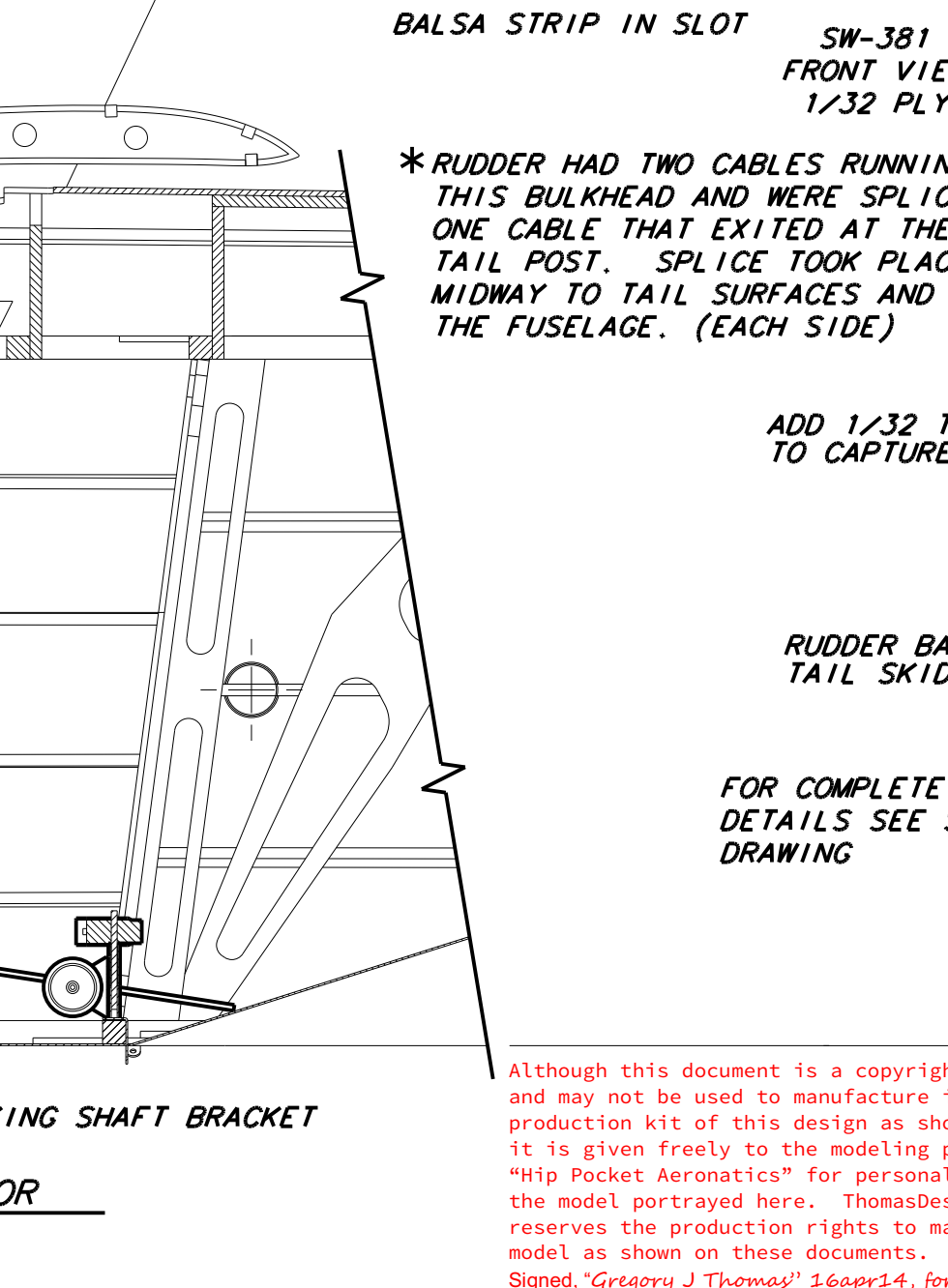
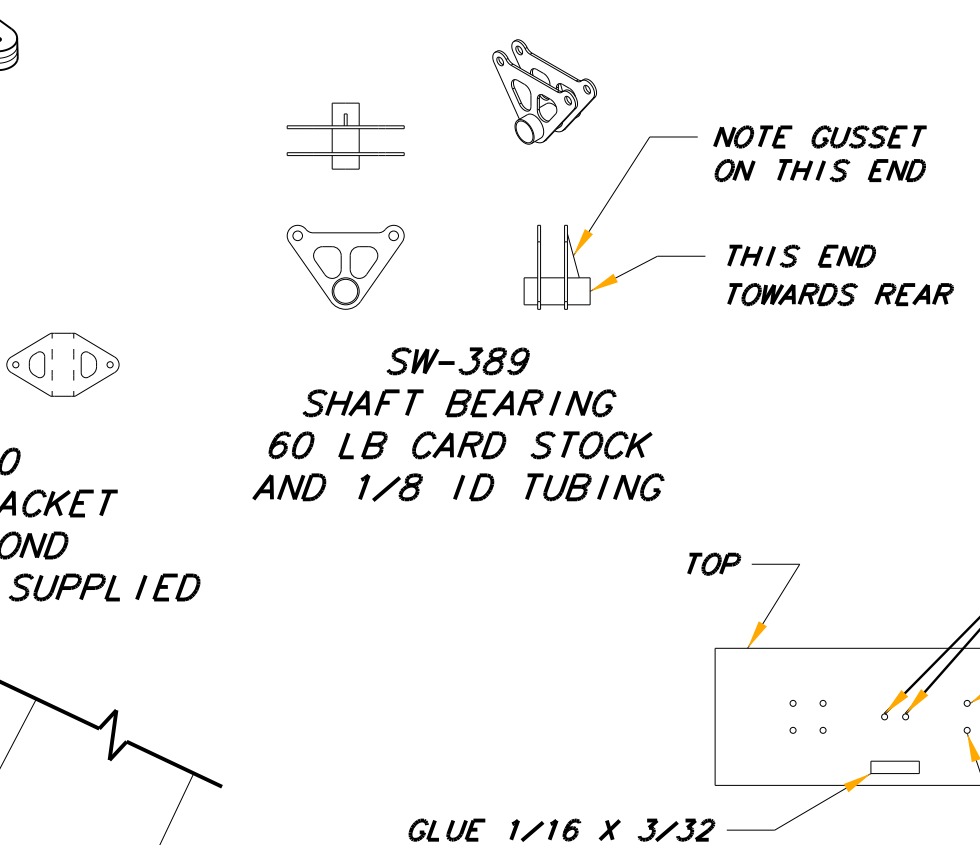
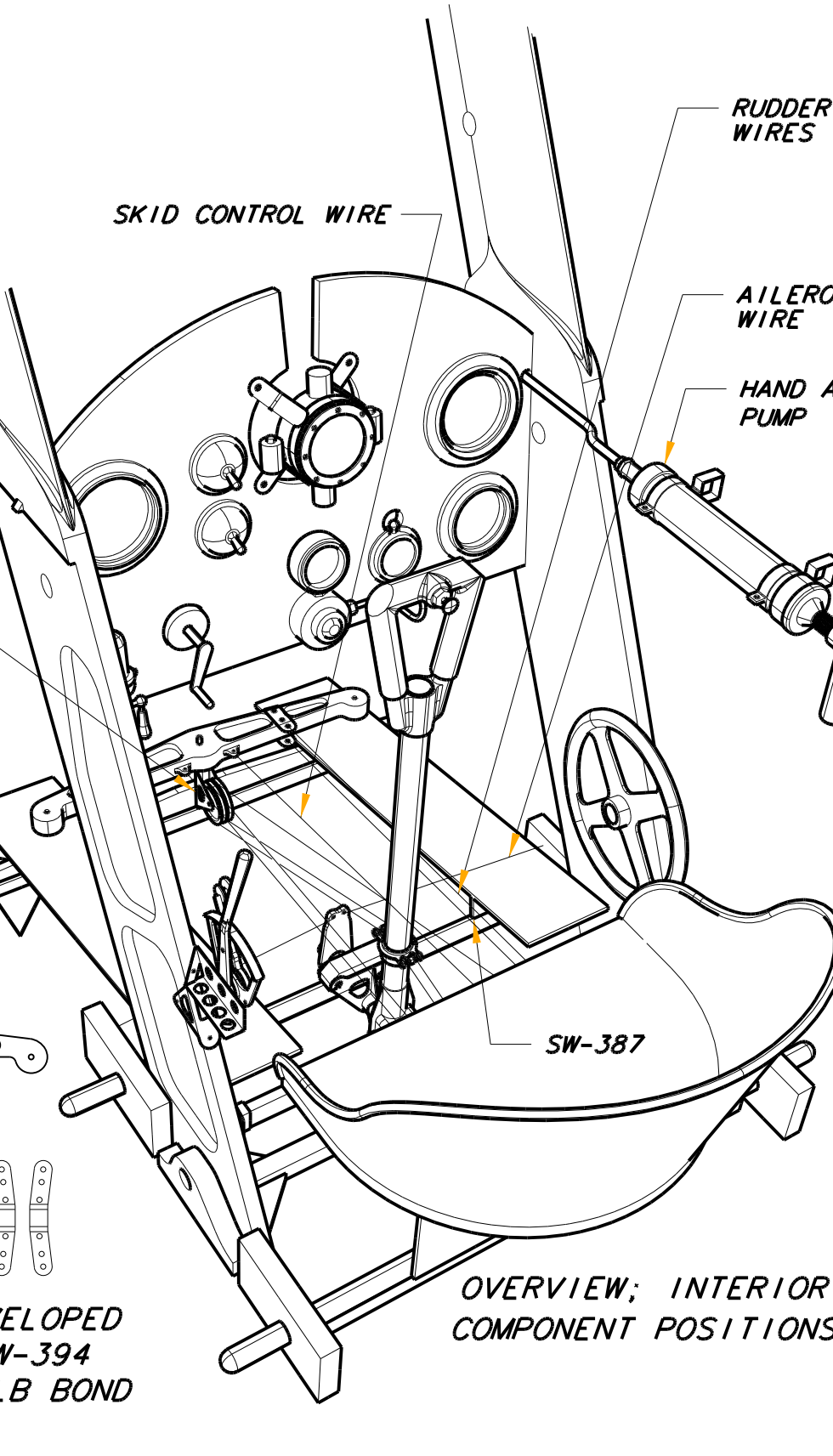
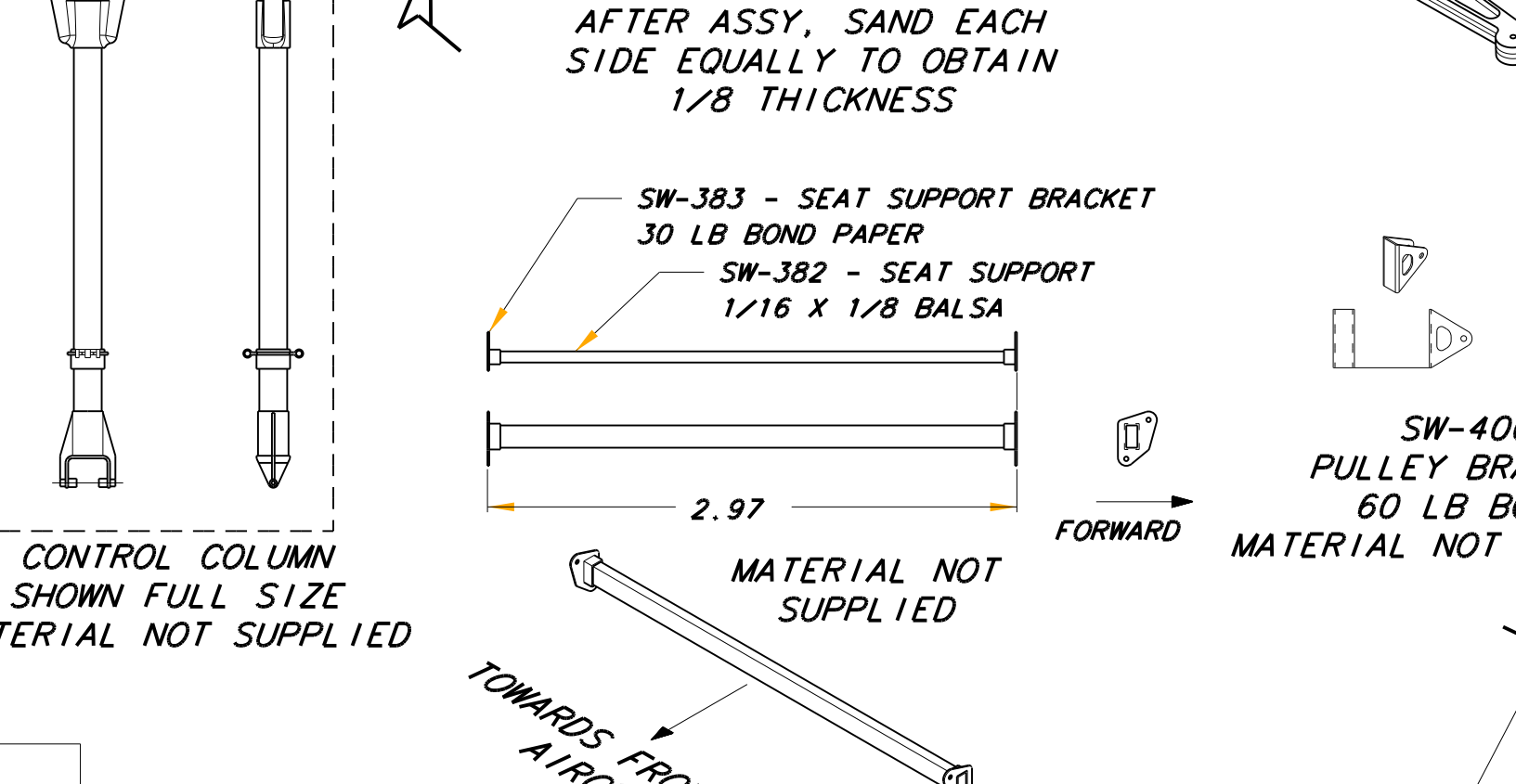
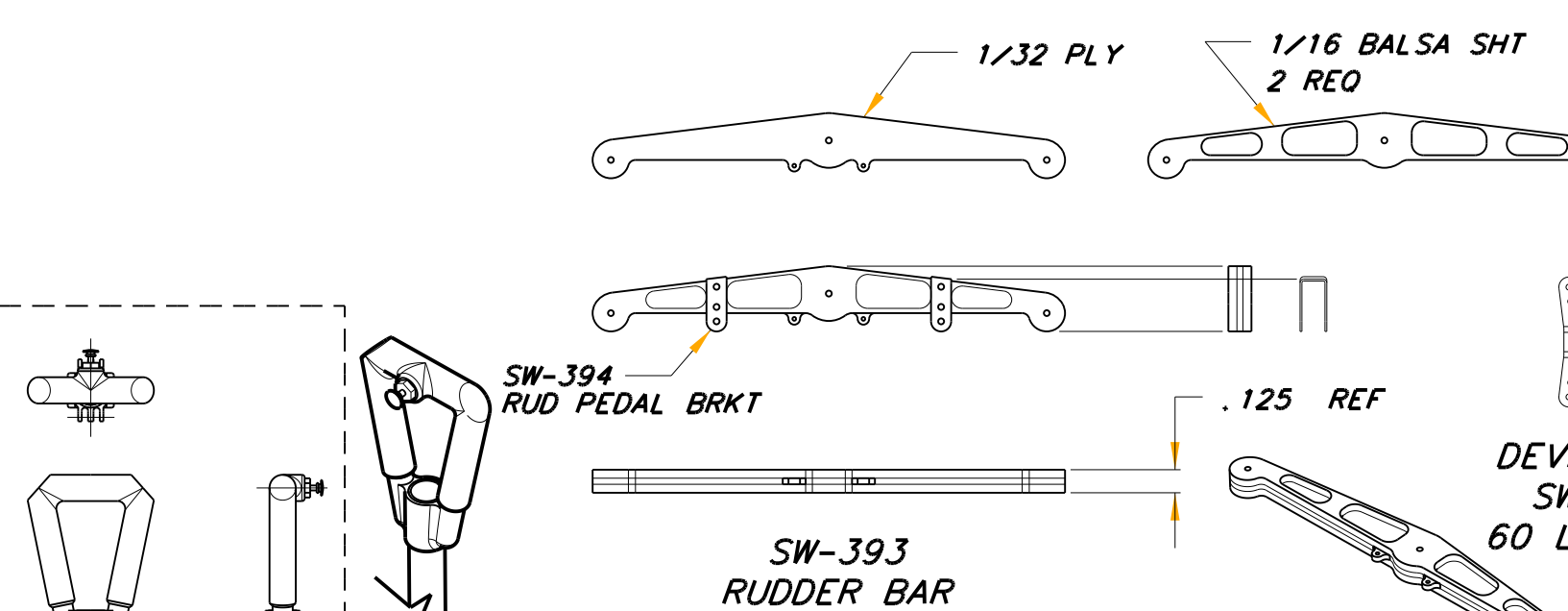
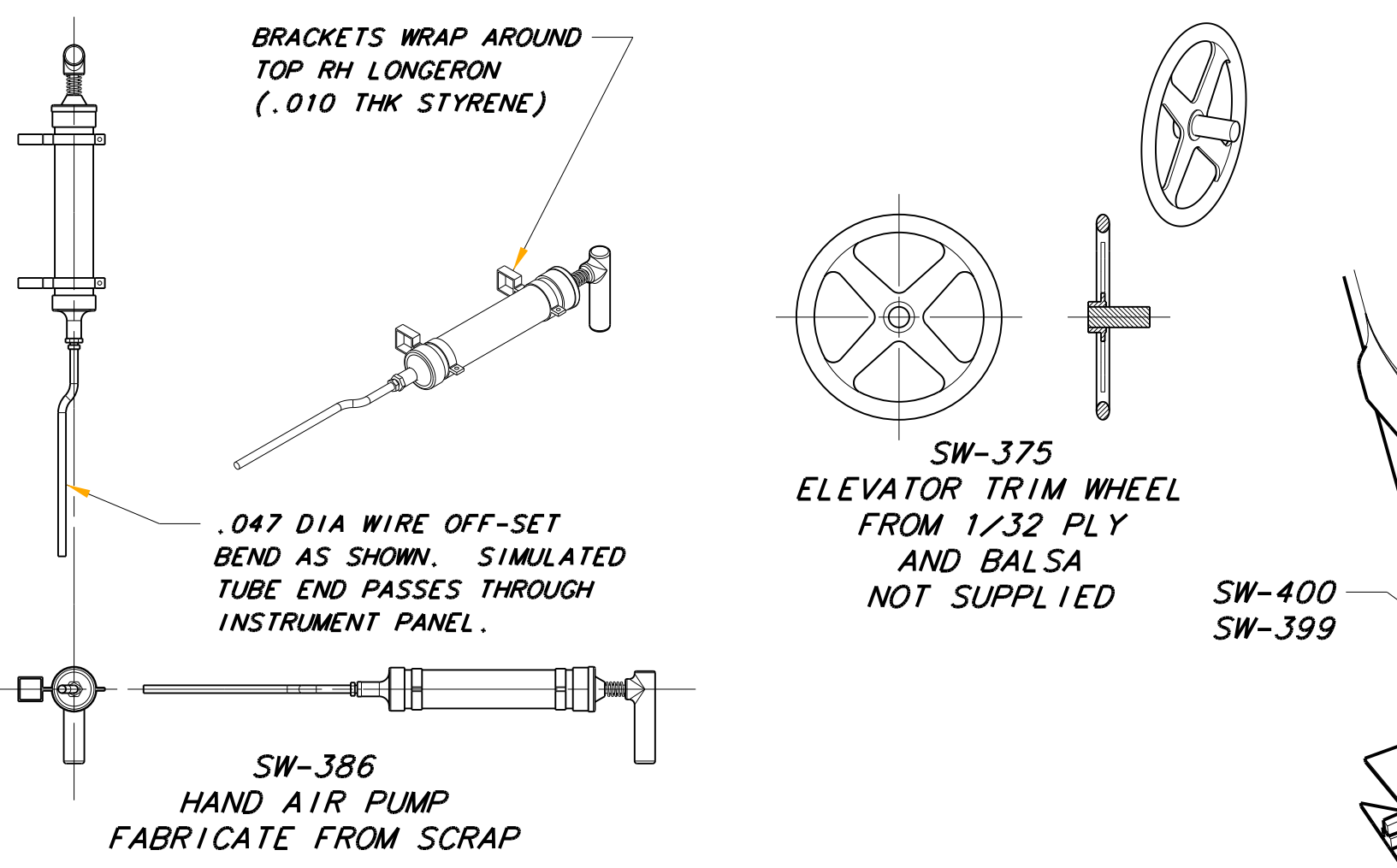
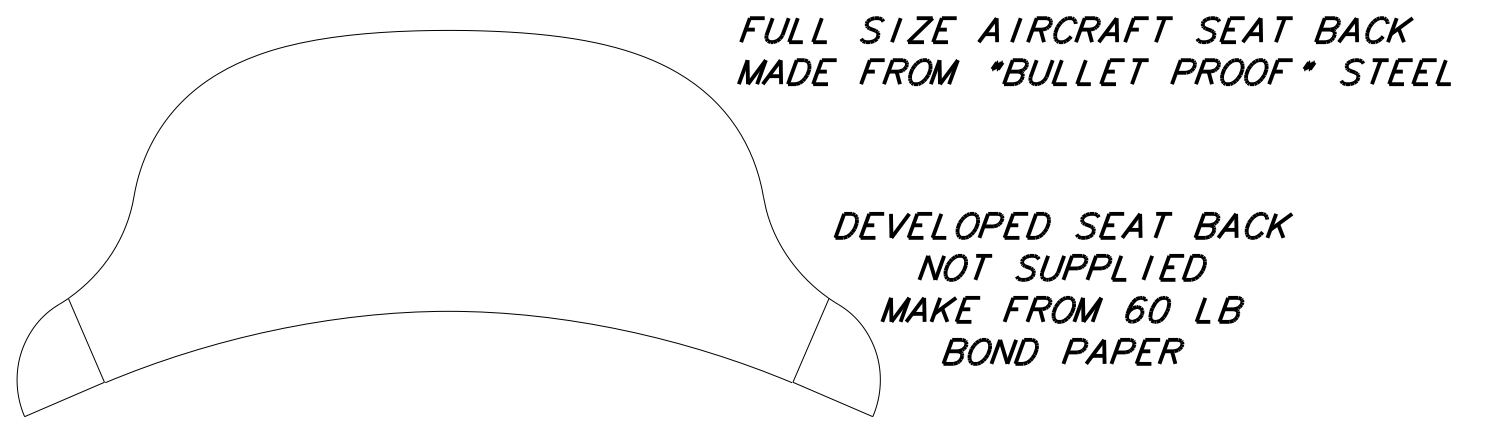
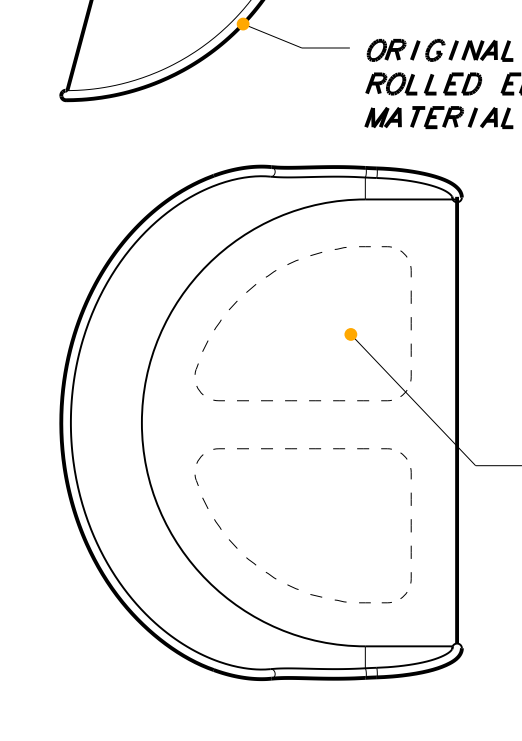
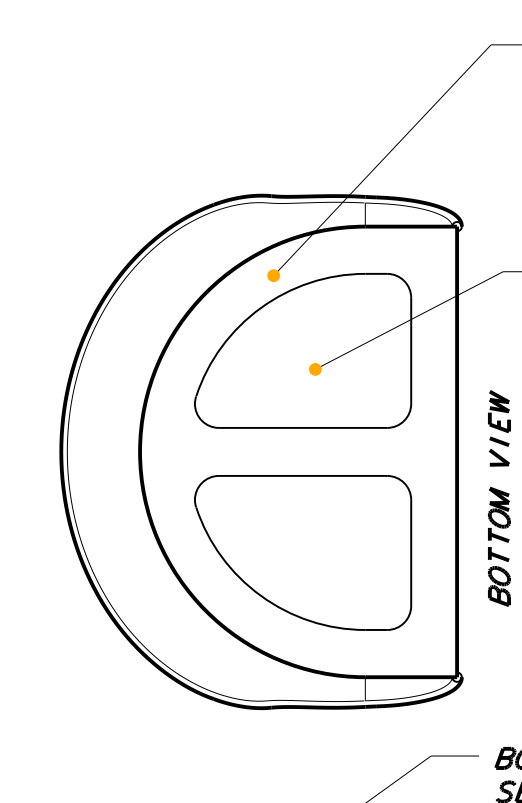

Although this document is a copyrighted document and may not be used to manufacture in any form, a production kit of this design as shown here, it is given freely to the modeling public via "Zip Pocket Aeronautics" for personal use in creating the model portrayed here. ThomasDesigns retains and reserves the production rights to manufacture the model as shown on these documents.
Signed, Gregory J Thomas 16Apr14, for ThomasDesigns