

**TOP SUB-WING ASSEMBLY**

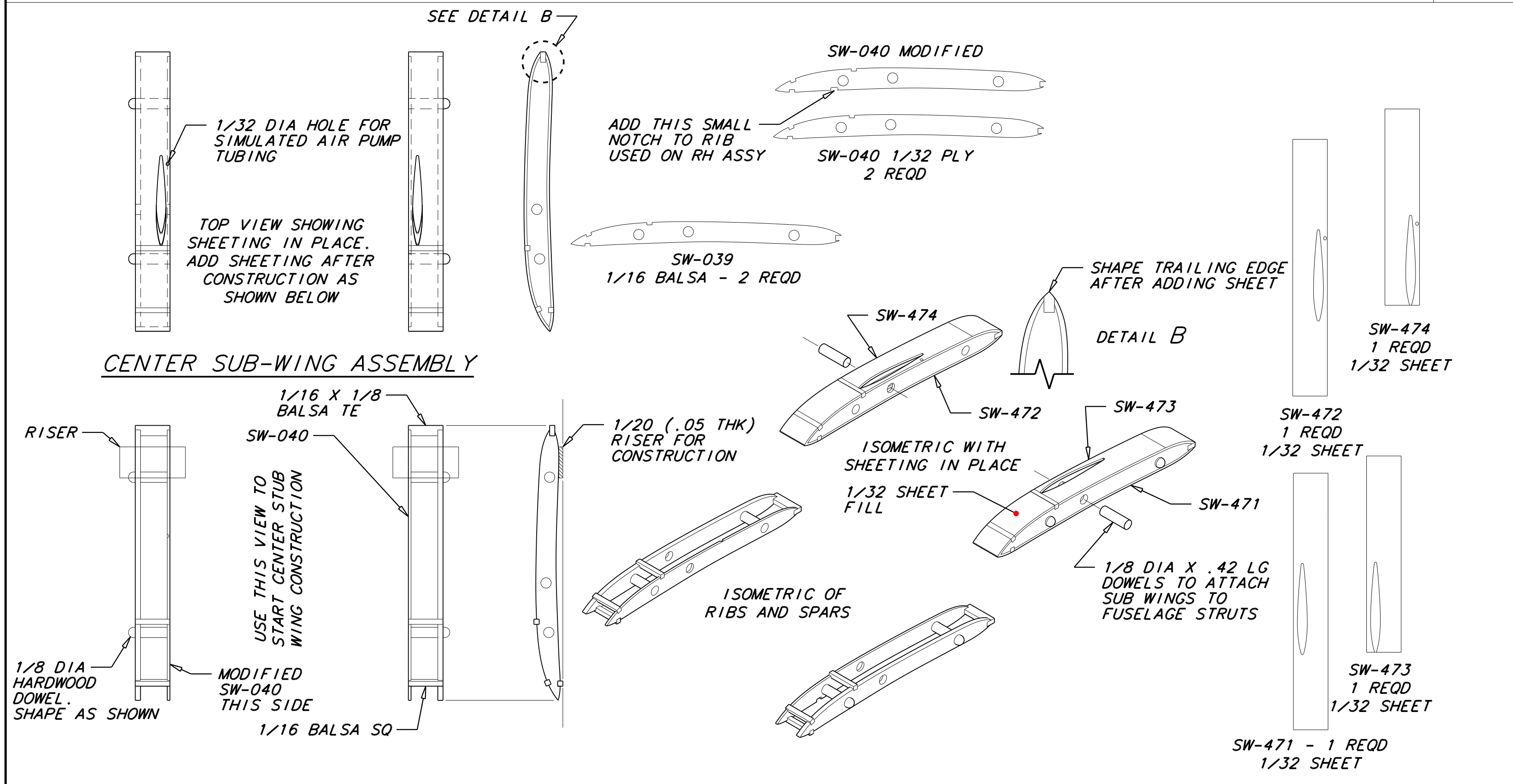
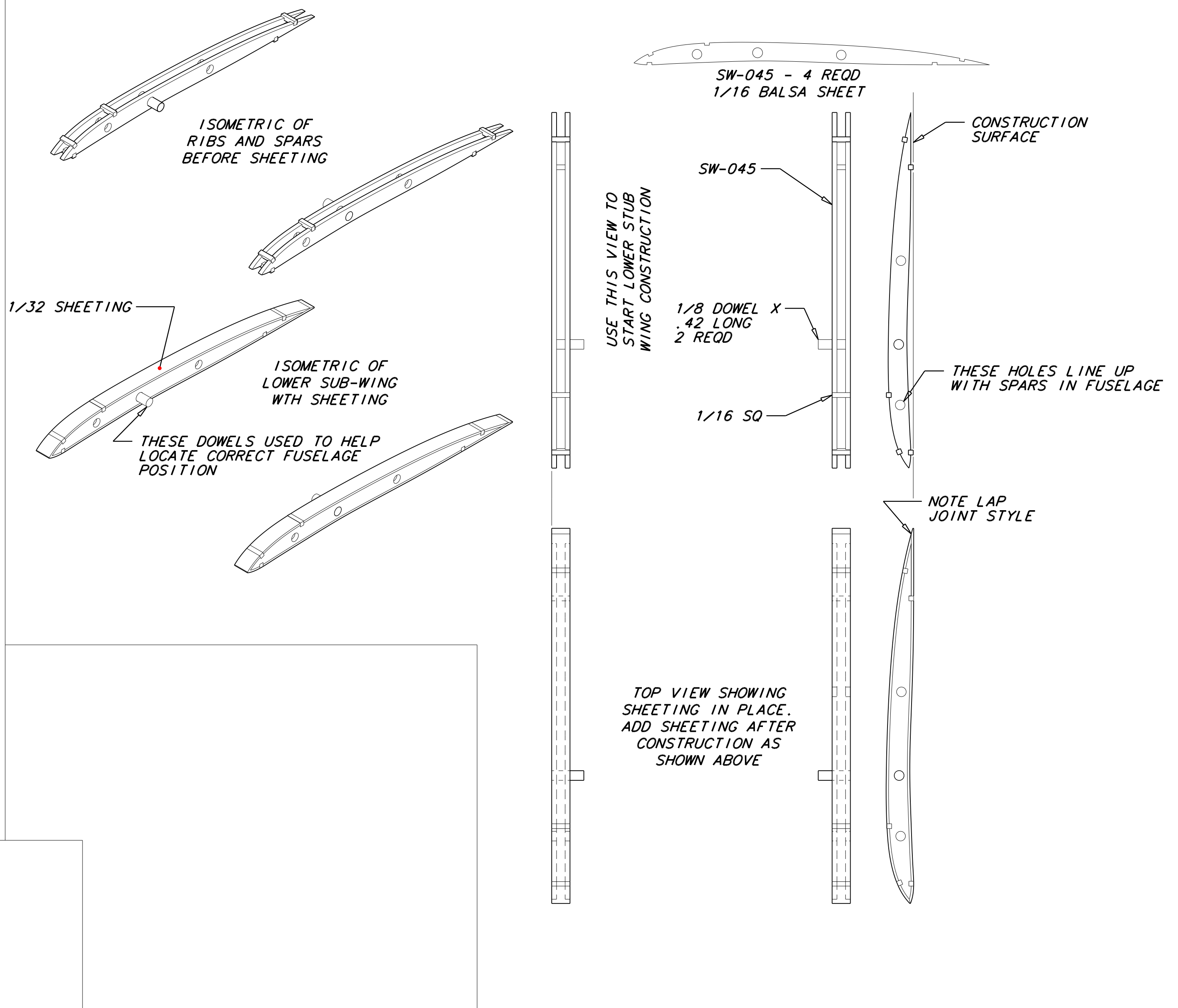

**CENTER SUB-WING ASSEMBLY**

Although this document is a copyrighted document and may not be used to manufacture in any form, a production kit of this design as shown here, it is given freely to the modeling public via "Hip Pocket Aeronautics" for personal use in creating the model portrayed here. ThomasDesigns retains and reserves the production rights to manufacture the model as shown on these documents.  
Signed, Gregory J Thomas' 16Apr14, for ThomasDesigns