

Aviatik D.I

By P M Grosz



WINDSOCK DATAFILE 45

FOREWORD

ON THE COVER:

FALL OF THE EAGLE

It is the morning of July 31 1918, Austro-Hungarian air ace *Oberleutnant* Frank Linke-Crawford flying D.I 115.32 is attacked by fighters of the 81^a *Squadriglia* although structural failure of the Aviatik's wings was doubtless the main contributing factor of the LFT pilot's downfall. Victor of 27 combats Linke-Crawford was 24 when he was killed. (Detail from an original painting by James Dietz)

I. Aviatik D.I 38.02 (in the foreground – see also colour plate 1) came to *Fluggeschwader* 1 (later *Flik* 101G) in late May-early June 1917 for Front-line evaluation at Sesana. *Hauptmann* Godwin Brumowski took the opportunity to fly 38.02 on June 17 and 26, the only time during his combat career that he flew the Aviatik D.I. It has not been reported what he thought of the new fighter, but he must have shared the opinion of other fighter pilots who regarded the angled gun mounted over the top wing as totally unsuitable for combat. The next fighter in the line is the Aviatik D.I 38.01 followed by a Hansa-Brandenburg D.I(Ph) series 28 fighter that Brumowski flew until gradually replaced by the Albatros D.III(Oef) fighter. The photograph was taken in September 1917.

▼2



▲1

For our third Austro-Hungarian *DATAFILE* subject we turn to the Aviatik D.I, the first fighter aeroplane designed in Austro-Hungary to enter LFT service. The D.I was produced in four series by its parent company and a further 12 under licence by five other manufacturers while its armament underwent considerable development. As a result there were many variations of detail and author Peter Grosz draws on his extensive archives to present a valuable pictorial guide while Steve Simkin's scale drawings are a further vital aid to

modellers striving to sort out all the different configurations. The D.I was flown by many of the LFT's top airmen, one such being *Offizierstellvertreter* Friedrich Hefty of *Flik* 28 who would later recall that the type possessed, . . . 'Excellent flying characteristics; it could outclimb any enemy plane, needed only a short take-off run, and was as fast as any other (aeroplane) at the time – in its final form it was the equal of the *Spad*'

As good a tribute as any to Julius von Berg's feisty fighter.

Ray Rimell, May 1994.



UK PRICE £6.50 (NET)

AN INTRODUCTION

The Aviatik D.I fighter is significant in that it was the first indigenous fighter designed and built in the Dual Monarchy to enter *Luftfahrtruppe* (LFT — Aviation Troops) service.¹ The successful debut of the three D.I prototypes launched a broad manufacturing programme involving six manufacturers that would account for 43 percent of the total fighter acceptances through October 1918.

Aviatik chief engineer Julius von Berg submitted the fighter design to the *Fliegerarsenal* (*Flars* — Aviation arsenal) on June 8 1916, but the proposal was disapproved because Aviatik was directed to devote full time to the Knoller programme.² When he got wind of the delay, *Oberst*. Emil Uzelac, commander of the LFT, vigorously intervened and construction of the D.I prototype (30.14) began in August. Although the prototype was destroyed on the maiden flight on October 16 1916, the D.I project proceeded apace.

The first flight of the definitive D.I prototype (30.19) occurred on January 24 1917. *Flars* test pilot *Oberleutnant* Fekete reported on March 31 that the fighter possessed, 'fabulous climb and enormous manoeuvrability' and felt that any competent two-seater pilot should be able to fly the type without prior schooling. The second D.I prototype (30.20) failed the load test on March 17. After re-design of the upper wing, the D.I was released for production in April 1917.³

Aviatik D.I series 38, 138, 238 and 338

The first production machine, 38.01 was accepted on May 3 1917 and sent to *Fluggeschwader* I on May 15 1917 for service evaluation along with the 30.19 prototype. The first Aviatik D.I victory, an Italian Nieuport, was credited to the CO of *Fluggeschwader* I, *Hauptmann* Karl Sabeditsch flying 38.01 on August 20 1917.

Since the Aviatik C.I had encountered minor structural problems early in its service career, the production D.I airframes were strengthened accordingly. In August-September 1917, small numbers of the new Aviatik D.I began to reach front-line units. Pilots praised the performance and regarded the D.I as, 'having the best climb range of any fighter without sacrificing manoeuvrability. The flight characteristics exceed those of all contemporary fighters.' But these fine attributes were negated by the lack of a suitable gun synchronization mechanism. The Schwarzlose machine gun mounted on the top wing at a 15 degree angle to clear the airscrew arc was reported to be, 'utterly ineffective'. Even so, a few victories were recorded by skilful pilots. It was not until December 1917 that the D.I was delivered with twin synchronized machine guns. Placed alongside the engine they were out of the pilot's reach, making it impossible to clear jams. Trials of a re-designed airframe with guns mounted in front of the pilot were successfully concluded in mid-January 1918 and beginning June-July 1918,

2. *Oberleutnant* Frank Linke-Crawford's Aviatik D.I(Lo) 115.32 of *Flik* 60/J photographed on the Feltre airfield. In spite of the fact that Linke-Crawford had officially complained about the faulty Lohner-built D.I, he continued using it in combat. On July 31 1918, eye-witnesses reported that Linke-Crawford, pursued by enemy fighters, had just levelled out after a high-speed dive and spin when he was seen to be 'throwing papers overboard'. This impression is believed to have been given by shreds of fabric tearing from the wing as a result of the violent manoeuvres. As he throttled back to nurse his badly damaged machine home, he was shot down and killed.

3. It appears that this Aviatik D.I 38.03 remained at Aspern and Wiener-Neustadt for test purposes. On June 12 1917, *Flars* test pilot Antal Fehér almost cracked the '200 kilometer barrier' when he achieved a remarkable 197 km/h (122 mph) in this fighter that was fitted with a special airscrew for the occasion.

4. The available aircraft records show that Aviatik D.I 38.05, remained at Wiener-Neustadt for the duration of the war, possibly for use as an advanced trainer. In 1920, the complete airframe was offered for sale to the Czechoslovakian government.



▲3 ▼4



most D.I fighters were delivered with accessible, cowl-mounted guns.

Produced by Aviatik, Lloyd, Lohner, MAG, Thöne & Fiala and WKF, the Aviatik D.I remained in production until the war's end. Being structurally identical, one series did not follow another as might be expected, rather all series were built simultaneously — according to engine availability which had difficulty keeping pace with aircraft output. The D.I was ideally suited for licence manufacture because of the relatively simple design. Using wood and plywood with a minimum of complex contours and metalwork, the airframe was ideal for semi-skilled woodworkers to build. In April 1917, Lohner, MAG and Thöne & Fiala received large licence orders, followed by Lloyd and WFK in early 1918. As of October 31 1918 (the last month for which acceptance figures are available) a total of 677 D.I fighters had been accepted. Had production ended as scheduled in December 1918, a grand total of 983 fighters would have been delivered. (See page 167, *Austro-Hungarian Army Aircraft of World War One*.)

The Aviatik D.I series powered by the 200 Daimler engine were the most popular because of the superior climb and speed characteristics. Austro-Daimler brought out the 200 hp Daimler engine in early 1917. The power rating was increased by raising the compression ratio and the use of four valves per cylinder. British engineers who tested a captured Daimler engine (taken from aircraft 138.27) reported that it, '*possessed more originality in design than the majority of enemy engines up to the present time*' (July 1918).

The British technical evaluation of the captured D.I (enemy aircraft number AG 6 — see also pages 28-32,) provides some insight into the Aviatik design practice. The RFC evaluation concluded that:

... 'everything had been designed to meet the requirements of easy production; everything being kept simple as possible to this end. This does not mean workmanship is inferior. As a matter of fact, the workmanship is very good generally speaking, although the finish may be here and there of a slightly less polished order than is found on some machines.'

The wings and airframe were of simple construction, but of a, '*simplicity which does not result in scamped workmanship and hurried finish but which bears evidence of careful design, with ease of production always kept in mind*'. The timber employed for the wings was of excellent quality, better than that found in the average German machine. The simple fittings combined high strength with light weight. Welding was used to a much lesser extent as compared to German practice.

The wing was unusual in that the rib section had a pronounced reflex curvature towards the trailing edge and the rear third was remarkably narrow. This feature, introduced by Prof. Knoller, was said to reduce the centre of pressure travel and result in improved longitudinal stability. But the aerodynamic advantage was offset by the danger of fatigue failure caused by the constant flexing of the thin trailing edge. In fact, such failures were not uncommon. In response, Berg designed a stronger wing with additional ribs that reduced

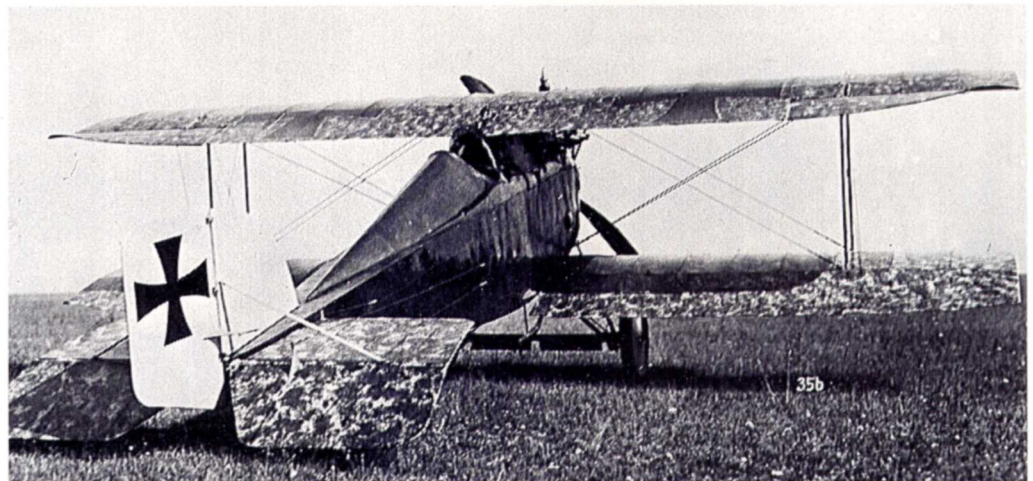

▲5 ▼6

5. The unarmed Aviatik D.I 38.06 was recorded as being assigned to the training command as of August 1917 and later attached to *Flek 6* at Wiener-Neustadt for fighter training. It too was offered to the Czechoslovakian government in 1920.

6. The brand-new Aviatik D.I 38.14 in the course of acceptance trials at Aspern in 1917. The record found for this fighter shows that it was flown by *Flik 23/D*.

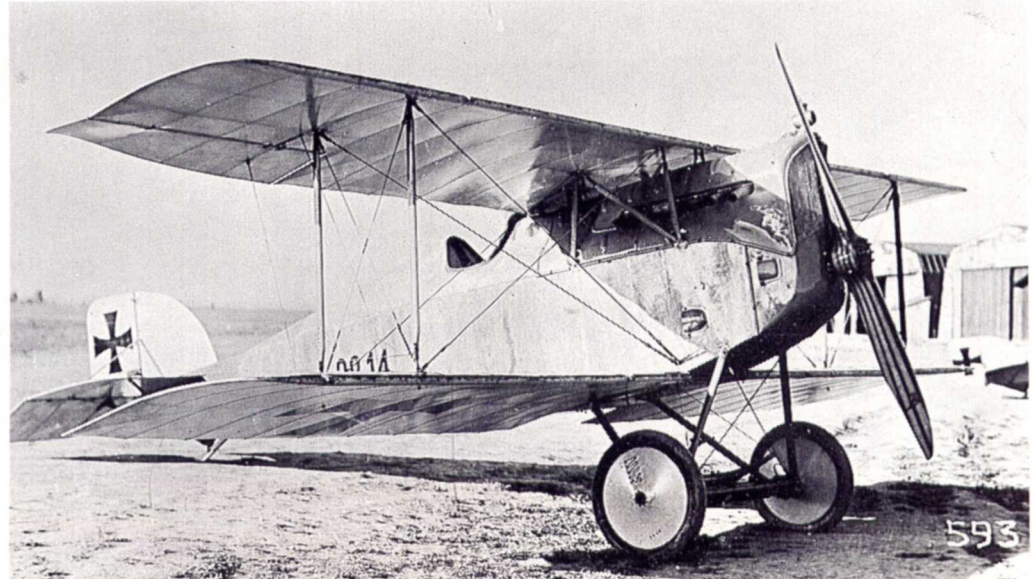

the rib spacing by half. The re-designed wing was introduced in July 1918, although the older wing continued in production possibly to use up existing stocks.

The chronic shortage of high-powered production engines set the stage for the next version of the Aviatik D.I fighter. Because ample reserves of new and reconditioned 160 hp Daimler engines were on hand, *Flars* tested an Aviatik D.I powered by that engine in December 1917. When it was concluded that the combination was capable of producing acceptable performance for operational purposes, the type was placed in production. The introduction of the *low-power* D.I series 238 fighter in April-May 1918 triggered universal condemnation. Pilots reported that the 160 hp fighter was too slow to intercept Allied observation machines much less compete with Allied fighters. In response, the LFT ordered the replacement of all 160 hp engines in the series 238 by 200 hp engines, when available, but few conversions were made.

By the middle of 1918, output of the new 225 hp Daimler engine was sufficient to power two production fighters, the Albatros D.III(Oef) series 253 and the Aviatik D.I series 338. Contracts for a total of 294 Aviatik D.I fighters powered by the 225-hp engine were awarded to Aviatik, Lohner, Lloyd and WKF. These aircraft had strengthened wings and engine bearers, and were armed with twin guns mounted at eye level. With the exception of a few fighters sent to the Front for evaluation, the Aviatik D.I series 338 arrived too late to have any impact.

Aviatik D.I(Lo) series 115 and 315

The LFT placed orders with Lohner for 165 Aviatik D.I(Lo) fighters. Shortly after the Lohner-built D.I series 115 fighters reached the Front in May 1918, five *Flik* 60/J aircraft experienced wing trailing edge failure. Investigation showed that Lohner had substituted a lighter rib section and had attached the fabric in a manner different than specified. The LFT ordered the series 115 fighters returned to the factory for wing replacement. Continued reports of failure led to swift if belated action. The 200 hp Daimler engines were ordered removed from the Lohner-built D.I series 115 fighters for use elsewhere; other machines were grounded or restricted to training duties. A handful of strengthened production machines remained operational but given the poor reputation, pilots preferred to fly other fighters. According to the records, none of the series 315 machines reached combat service.

Aviatik D.I(LI) Series 48, 248 and 348

In May 1918, the LFT ordered 100 Lloyd-built Aviatik D.I fighters. Most of the series 48 and 248 fighters were delivered and placed in storage before the war ended. A few were flown as trainers or assigned to (home) 'Defence Flight Winkler' in August 1918. A single Aviatik D.I(LI) series 348 fighter was accepted in September 1918 and the remaining series 348 machines were reported completed and awaiting acceptance at Aszód. After the war a handful were flown by the Hungarian air service.



▲7 ▼8

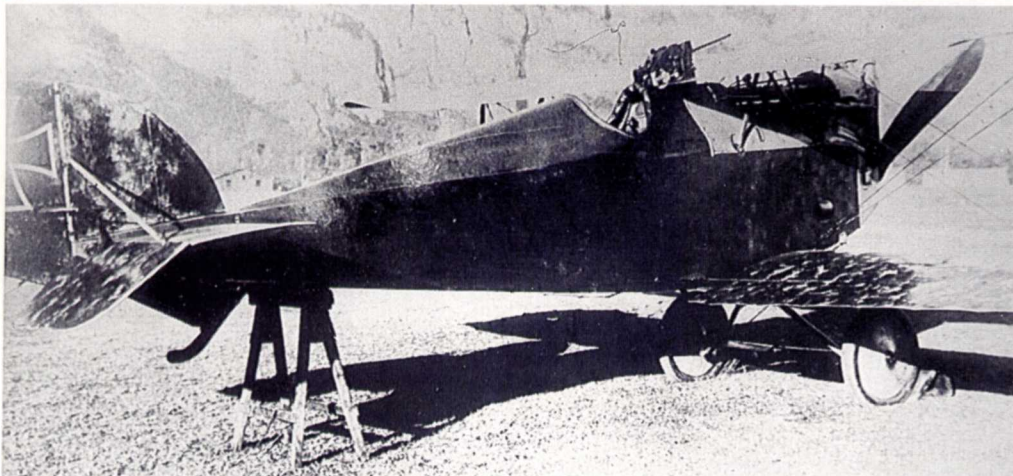

7. The pilot and his trusty mascot. It is known that aircraft D.I 38.15 served with *Fliks* 35/D and 4/D before use as a weapons' test vehicle at Aspern in 1918. The nose radiator with the round cooling louvre and characteristic condenser unit was typical throughout the D.I production run. It is obvious that the pilot's forward vision leaves something to be desired.

8. The rear view of Aviatik D.I 38.20 nicely demonstrates the awkward direction of the angled Schwarzlose machine gun. Pilots soon discovered that one had to attack the enemy in a dive if some measure of success was expected. Invariably this left the pilot below the enemy in a vulnerable position. The fighter served with *Flik* 17/D at Gardolo and also with *Fluggeschwader* I.

Aviatik D.I(WFK) series 84, 184, 284 and 384

A total of 98 Aviatik D.I (WFK) fighters were ordered from the WKF. Delivered late in the war, most of the series 84 remained in storage owing to the lack of engines. Only a single D.I series 184 fighter was accepted prior to October 31 1918. It joined *Flik 72/J* in June 1918. All D.I(WKF) series 284 fighters were accepted prior to September 1918. Confusion exists because WKF completed 24 additional series 284 airframes that were to receive the 225 hp Daimler engine and be re-designated series 384. However, before implementation, at least 35 series 284 fighters entered the records. Only a handful actually reached operational units before the war ended. Ten series 384 fighters powered by 225 hp Daimler engines were accepted as series 384 while still carrying their old numbers. However, it appears they never left the factory, for after the war, 40 series 384 airframes were stored at the WKF factory.

Aviatik D.I(MAG) series 92

A total of 172 Aviatik D.I(MAG) series 92 fighters were ordered by the LFT. When the type reached the Front in mid-1918, some

squadrons rejected the type because ... *'It is impossible to fly this aircraft over the enemy. . .the wing cellule is even weaker than that of the early Aviatik D.I fighters.'* It was found that aircraft below 92.50 had been manufactured according to the old Aviatik D.I drawings. When tested in a spin, the lower wing had a tendency to come apart. The quality of MAG workmanship was judged defective and slipshod. Although distributed among some units, the MAG-built D.I saw little combat. On October 10 1918, when *Flik 74/J* tested aircraft 92.18 fitted with reinforced wing ribs, it was found that at 150 km/h (93 mph — well below its top speed of 187 km/h) the upper wing trailing edge and the lower wing vibrated so severely that, ... *'one cannot develop trust in the aircraft.'*

Aviatik D.I(Th) series 101 and 201

A total of 60 Aviatik D.I(Th) fighters were ordered from Thöne & Fiala. Originally all Thöne & Fiala-built Aviatik D.I fighters were intended for training purposes and consequently had rebuilt engines installed. However, 20 series 101 and two series 201 fighters were listed in the Front-line inventory

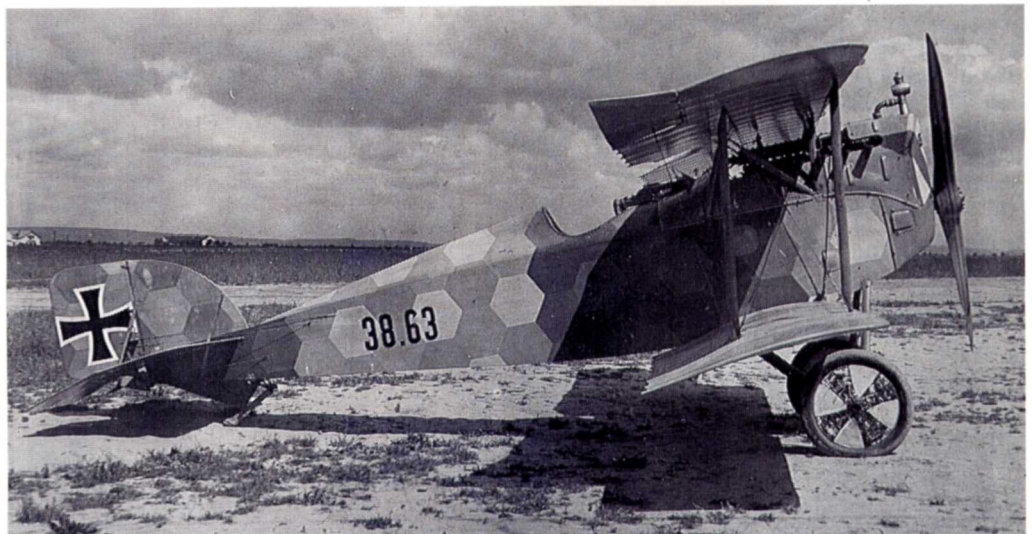

▲9 ▼10

9. As the war progressed, a variety of camouflage schemes were applied to Austro-Hungarian aircraft including the bold hexagon pattern. Aircraft D.I 38.63, among the first fitted with the cowl-mounted guns, was ordered dispatched to the Front on July 20 1918. *Korporal* Josef Marszalek of *Flik 74/J* was wounded on July 15 1918 when the fighter crashed due to wing failure.

10. A motley group of *Flik* mechanics posing with an unidentified Aviatik-built D.I. The indented engine panelling shows the steps taken to improve visibility. The fighter is an early production example since it lacks synchronized guns.



in August 1918. The only recorded combat service was with *Flik 31/P* as a photo-reconnaissance fighter.

Conclusion

Looking back, it can be said that the Aviatik D.I was unique in two respects. It was the first operational fighter developed by an Austro-Hungarian manufacturer and it was built in larger numbers than any other Austro-Hungarian fighter. In a report submitted to the Austrian parliament in May 1917, *Graf Adalbert Sternberg* stated that the Berg projects had been summarily rejected because Aviatik was to concentrate on the Knoller programme. Sternberg pointed out that, ... 'had the single and two-seater projects been intelligently analyzed and supported by Flars, then today's Berg aircraft (ie: Aviatik D.I and C.I) would have been at the Front in the autumn of 1916.' If that had been the case, then the D.I fighter might have made a difference, but by late 1917 when significant numbers of the D.I began to reach combat service, it was already outclassed by superior Austro-Hungarian and Allied fighters. The Aviatik D.I played its part to the end, but it

did so as a second-rank machine by 1918 standards.

Editor's note

The above material has been excerpted and condensed from the book *Austro-Hungarian Army Aircraft of World War One*, that includes additional information and photos. The book is available from Flying Machines Press, 1216 Cuernavaca Circulo, Mountain View, CA 94040, USA and can be ordered directly from the publisher: Single copy price including shipping: USA \$91; Canada and Mexico \$94.50; outside North America \$95.50. Cheques and money orders accepted in US \$ and British £ at current exchange rate. Visa Card orders also accepted. □

Notes

1 The Oesterreichisch-Ungarische Flugzeugfabrik "Aviatik" was founded by the German Aviatik company and the Weiser company of Vienna. By 1917, the oest-ung Aviatik firm was independent as far as aircraft design was concerned.

2 The Knoller programme was a broad construction programme to build a high-performance, two-seat biplane designed by Professor Richard Knoeller. The design proved faulty and after much expenditure of time and money the programme was cancelled amidst angry recriminations.

3 On the squadron level and in official documents, the Aviatik D.I was often referred to as the Berg fighter.

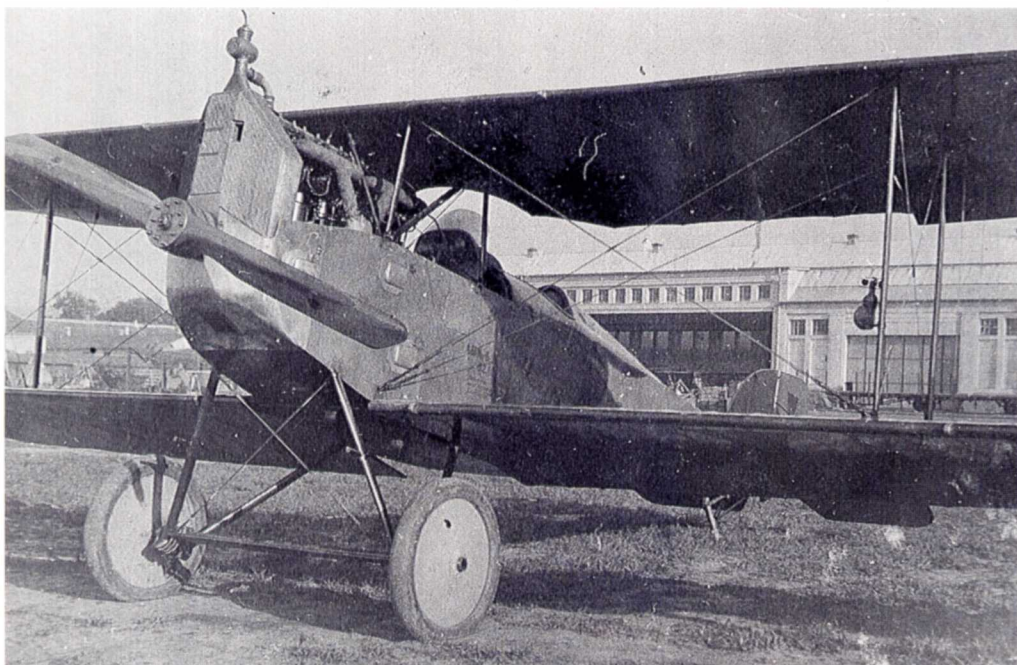

▲11 ▼12



11. Aviatik D.I(MAG) 92.18 in front of the MAG hangar in Mátyásföld. This aircraft, fitted with strengthened wing ribs, was tested by *Flik 72/J* on October 10 1918. The slot in the radiator is for the port machine gun which remains to be installed as does the engine panelling.

12. The beautifully-finished and factory-new MAG-built D.I 92.24 that was dispatched to the Front in July 1918.

13. With the introduction of phosphor tracer ammunition, spontaneous ignition in the hot Summer months became a problem for both the German and Austro-Hungarian air services. Here Aviatik D.I(Lo) 115.45 of the fighter school in Pergine caught fire on June 8 1918.

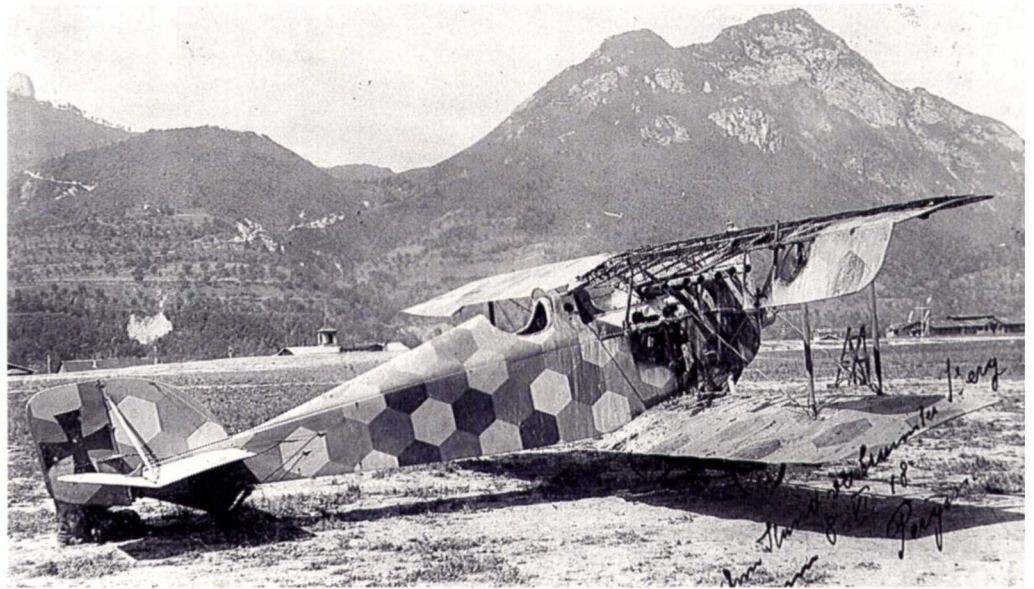

▲13

14. Sporting an interesting camouflage pattern, the Aviatik D.I series 138 was built in parallel with series 38 beginning September 1917 and continuing through August 1918. Records show that D.I 138.07 was attached to *Flik 15/F*, *Flik 60/J* and *Flik 14/J*. It appears that this machine was not fitted with synchronized guns.

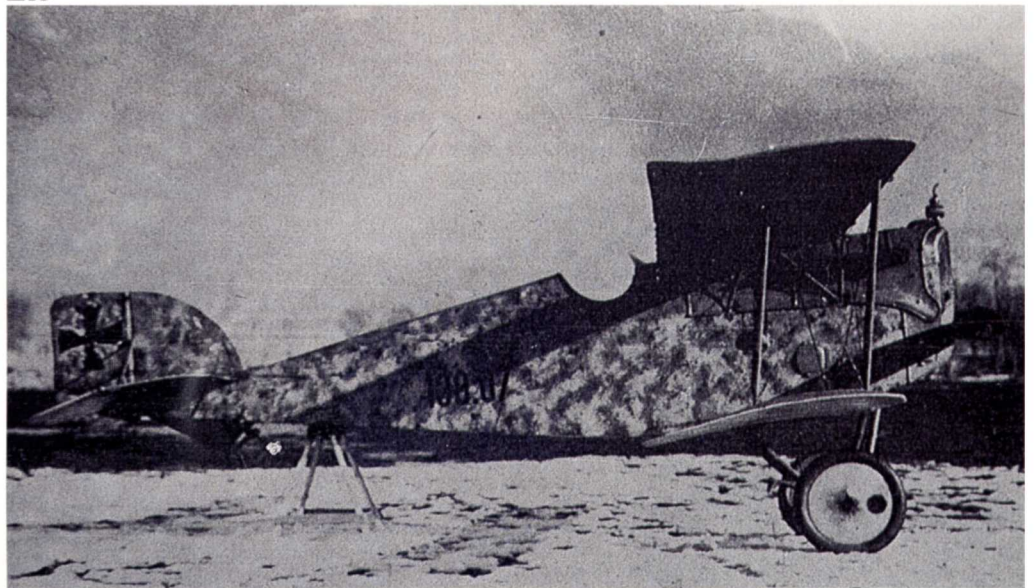

▲14 ▼15

15. A colourful variety of markings and camouflage finishes photographed in Wiener-Neustadt in 1920 as Aviatik D.I machines await destruction in accordance with Interallied Commission directives. From left to right: 115.26, 115.24, 115.30, 115.05, 138.24 'P' and Aviatik C.I(Lo) 114.16.





▲16

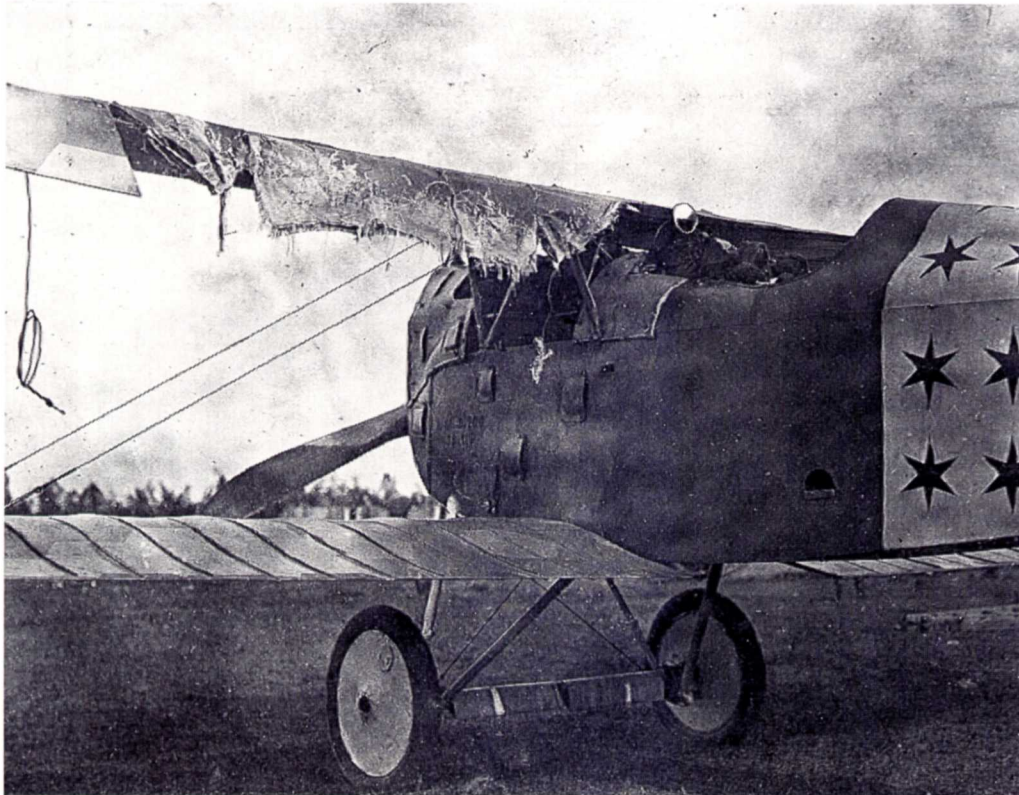

▲17 ▼18



16. Two Aviatik D.I fighters (138.98 and 138.114) were evaluated by the German test centre at Adlershof in March-April 1918. Here 138.14 shows off the non-symmetrical, four-bladed airscrew composed of two separate units bolted together. *Idflieg* (Inspectorate of Aviation Troops) reported that the D.I demonstrated better climb and speed than the Albatros D.V but was not as manoeuvrable.

17. The thin trailing-edge rib section was purposely designed to flex so that it would flatten with increasing air speed. In flight the constant vibration could cause massive fatigue failure, even in a strengthened wing as shown here. *Korporal* Alfred Wiesinger of *Flik* 74/J piloting Aviatik D.I 138.119 was fortunate to land safely on September 18 1918. The rear-view mirror on the centre section gave some protection from being jumped from behind.

18. Aviatik D.I 138.24 served with *Flik* 24/F. Like many early series 138 machines, the example is fitted with an angled machine gun, the muzzle of which is just visible over the top wing. In addition to being robust, the square plywood-covered fuselage facilitated production.



▲19



▲20 ▼21

19. *Feldpilot Korporal* Josef Kunz of *Flik 74/J* crashed fatally on August 29 1918 while flying Aviatik D.I 138.55 *Mizzi*. The signal flare pistol is mounted aside the cockpit. The fighter was armed with twin synchronized machine-guns, mounted astride the engine, out of reach of the pilot.

20. *Leutnant* Othmar Wolfan of *Flik 56/J* in his Aviatik D.I 138.54. The twin, cowl-mounted accessible guns were preferred by most pilots even though the oil mist from the cartridge lubrication system tended to obscure the pilot's vision.

21. An Aviatik D.I series 138 fighter, here flown by *Leutnant* Makowitz of *Flik 72/J* at San Fior in May 1918. The prominent radiator condenser unit, a characteristic of the nose radiator, was also seen on MAG-built Fokker D.VII fighters. The front gun sight is mounted above the forward exhaust pipe.

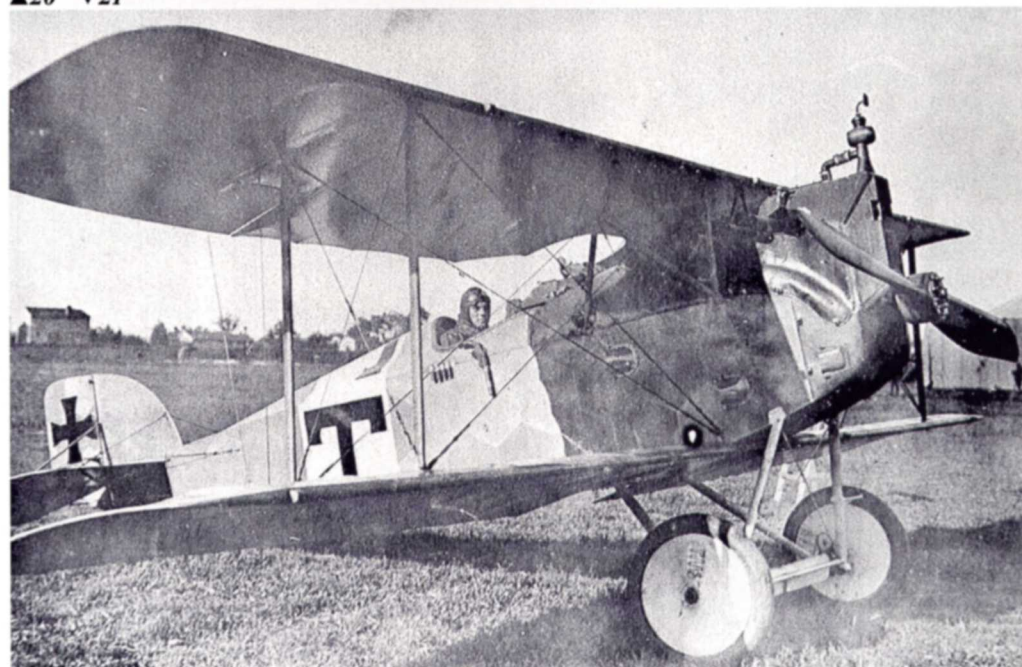



▲22

22. The chronic shortage of high-powered production engines set the stage for the Aviatik D.I series 238 fighter. Because ample stocks of new and reconditioned 160 hp Daimler engines were on hand, *Flars* ordered 120 of the type. By mid-1918, Aviatik fighters were coming off the production line exemplified by the Aviatik D.I 238.82 given lowered decking in front of the pilot to accommodate the raised guns. To improve forward visibility side radiators were installed. This machine was sent to the Front on July 20 1918.

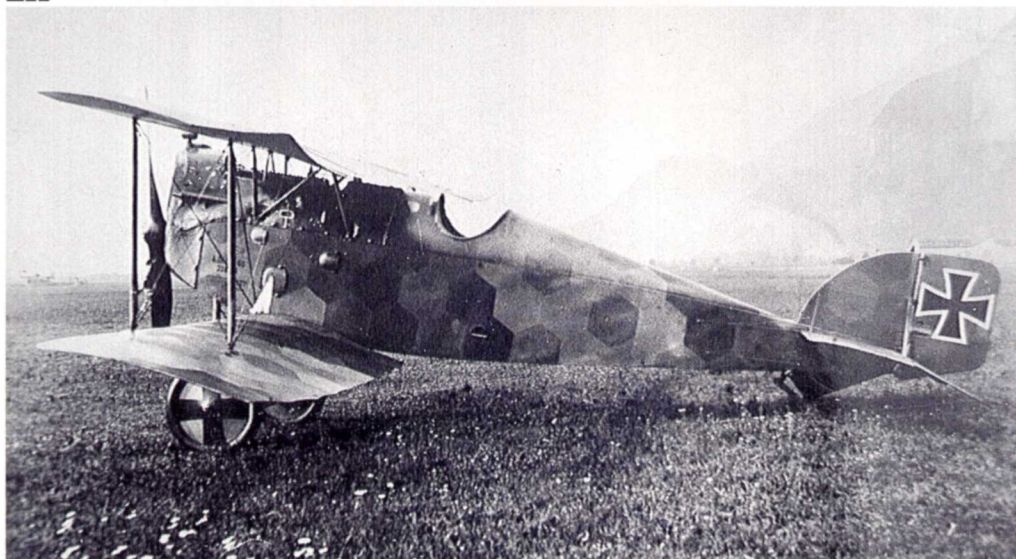

▲23 ▼24

23. The Aviatik D.I 238.25 with nose radiator and buried machine guns was delivered from the factory in March 1918. It was attached to *Flik 23/D* and lost on August 17 1918. Regarded as underpowered, the series 238 was quickly relegated to training duties, or re-fitted with more powerful engines to make it a viable combat machine.



24. Unlike the conditions on the French Front, the war in Italy was often fought in forbidding mountainous terrain that placed a premium on engine reliability. Aviatik D.I 238.48, possibly fitted with a 185 or 200 hp Daimler engine, was attached to *Flik 55/J* at Pergine in 1918. The deep cockpit protected the pilot, but restricted his forward vision.

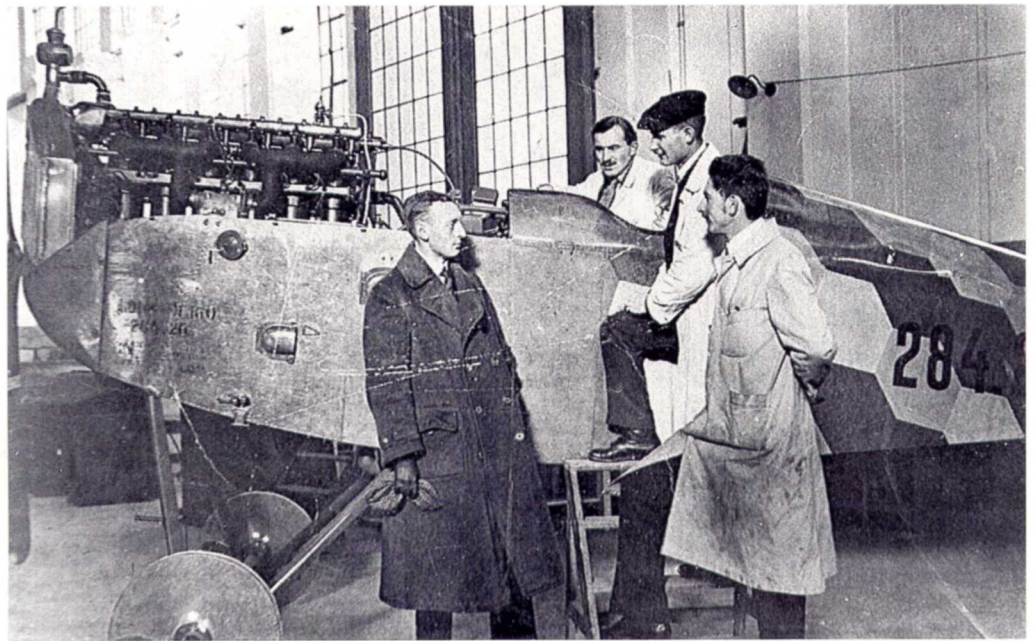

▲25



▲26 ▼27

25. WKF personnel assembling an Aviatik D.I(WKF) 284.26. It was powered by a 160 hp Daimler engine. As far as is known, the type did not reach the Front.

26. Aviatik D.I series 338 fighters began to reach the Front in September 1918, but only very few saw combat service in the waning days of the war. This D.I 338.38 was downed or found by the Italians, who are inspecting the airframe at Egna on November 10 1918.

27. An unarmed Aviatik D.I 388.53 photographed at Aspern after the war. The large leading-edge radiator seen only on the D.I fighters powered by the 225 hp Daimler engine. The thin wing structure made it difficult to install an aerofoil radiator.

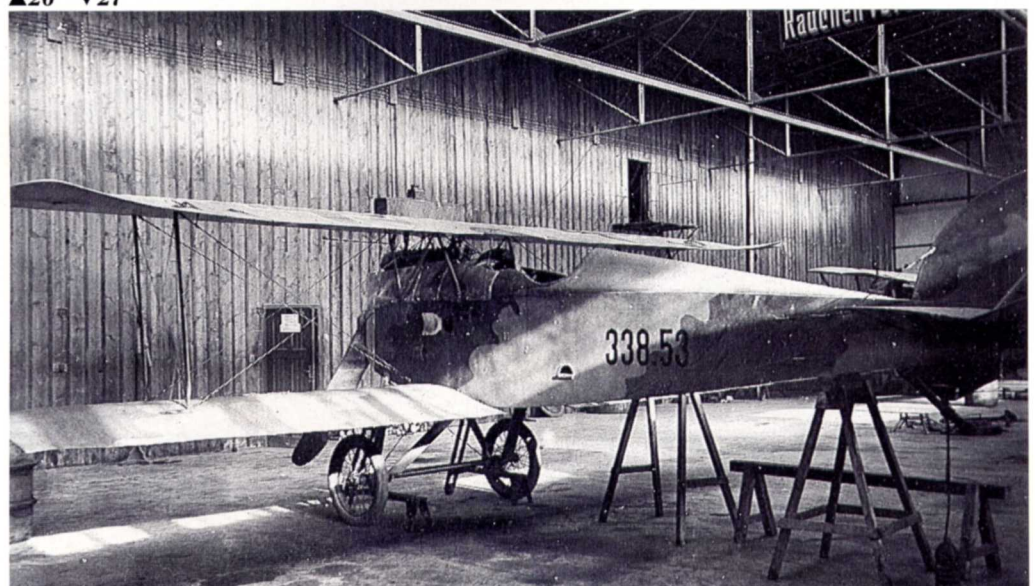



▲28 ▼29

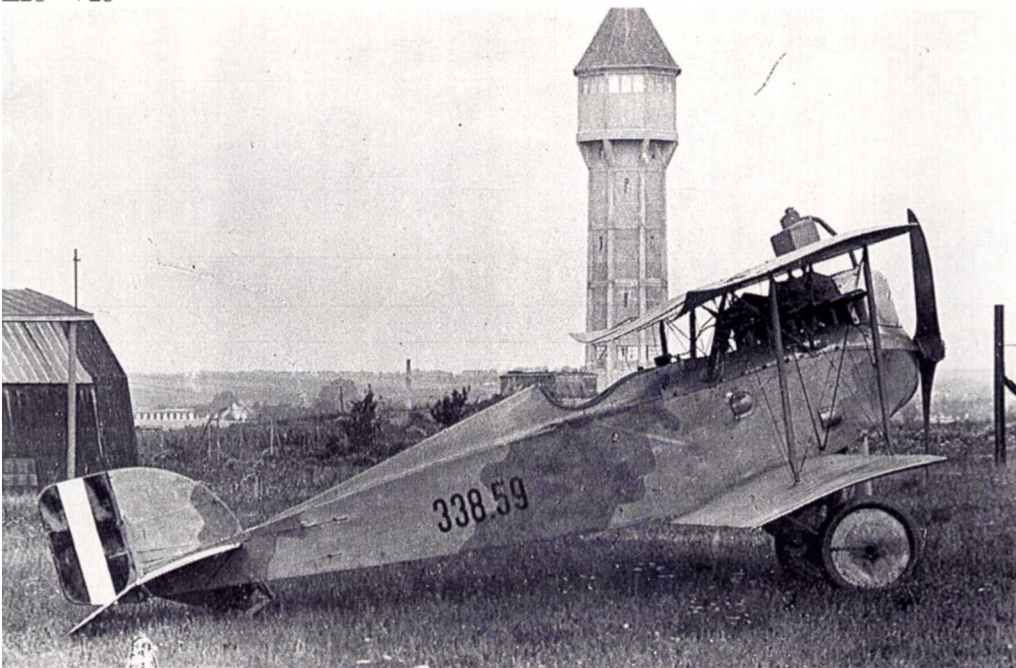

28. The close-up of this Aviatik D.I (probably a series 38) provides a wealth of detail including the wheel chocks. The airman has not been identified.

29. An unarmed Aviatik D.I 338.59 carrying the tail insignia of the Austrian *Volkswehr* at Fischamend in 1919.

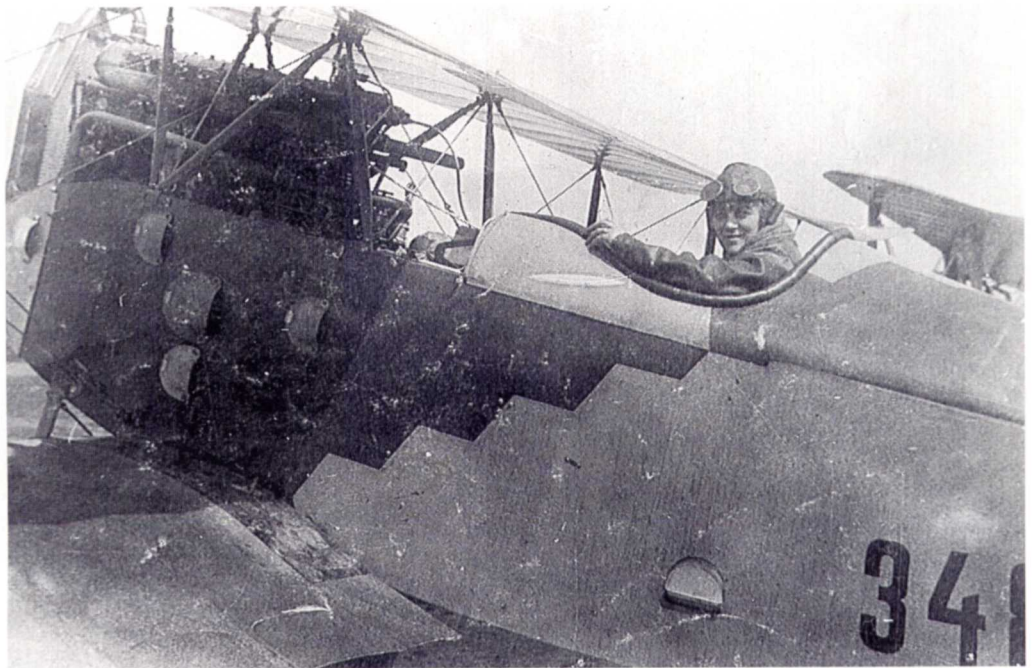

▲30



▲31 ▼32

30. One of the few extant photographs of a Lloyd-built Aviatik D.I. Here is D.I(LI) 348.01 at Aspern for acceptance trials in September 1918. The machine guns and engine panels remain to be installed.

31. An Aviatik D.I(Th) series 101 with the Austrian civil registry A.36. According to several sources, pilot Franz Zusmann lengthened the fuselage, but it does not appear to be the case in this photograph.

32. Aviatik D.I(Th) series 101, Austrian registry A.36, was still flying in 1927.

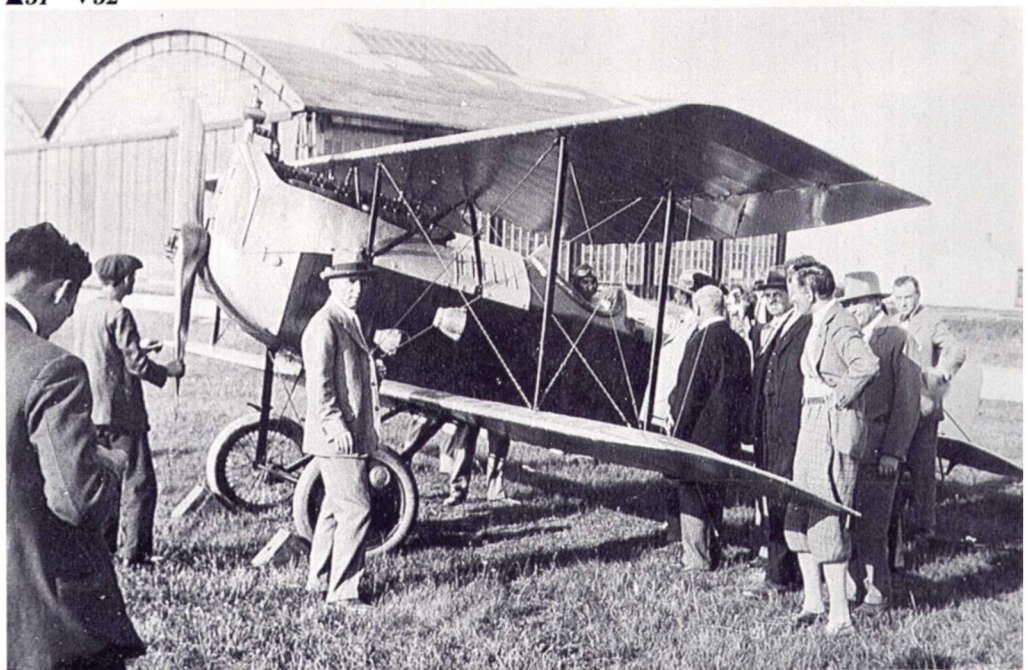

General note - seven configurations of the Aviatik D.I are shown on sheets 1,2&3 however many detail variations of each type existed. Also machines in a production series rarely had a common configuration.

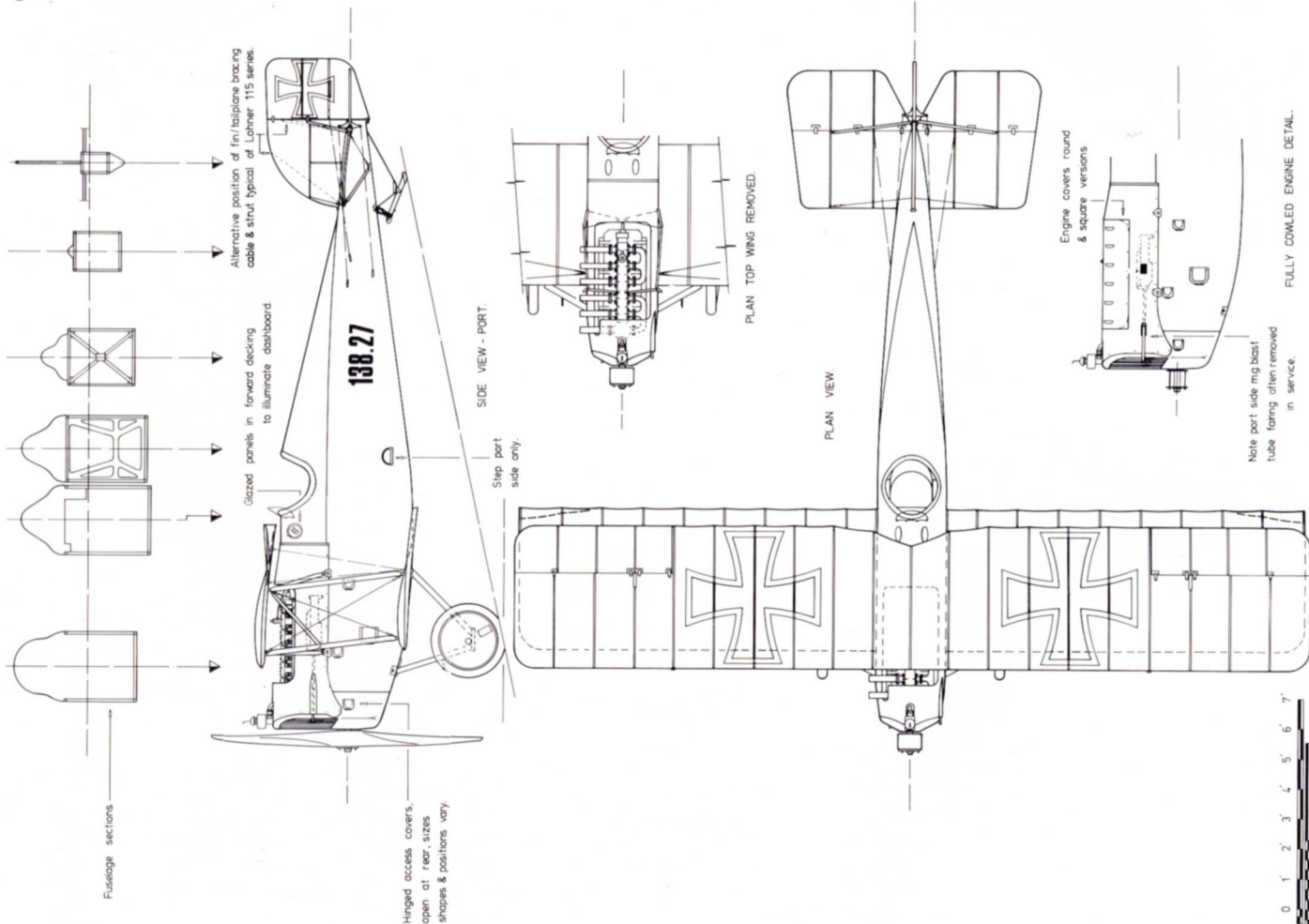

AVIATIK D.I. FITTED WITH ROUNDED RADIATOR AND M.G.'S MOUNTED ALONG SIDE THE ENGINE.



For wing details see 38.63 sheet 2.

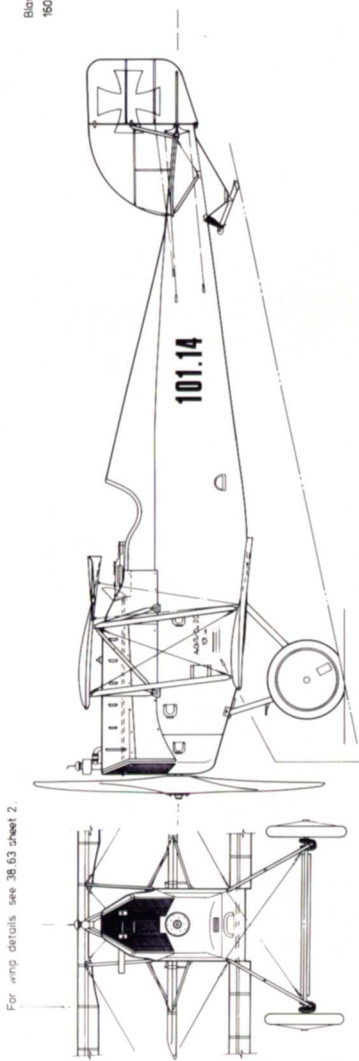

ADL 14-0-210
101.14
BUILT BY THONE & FIALA

101.14 BUILT BY THONE & FIALA

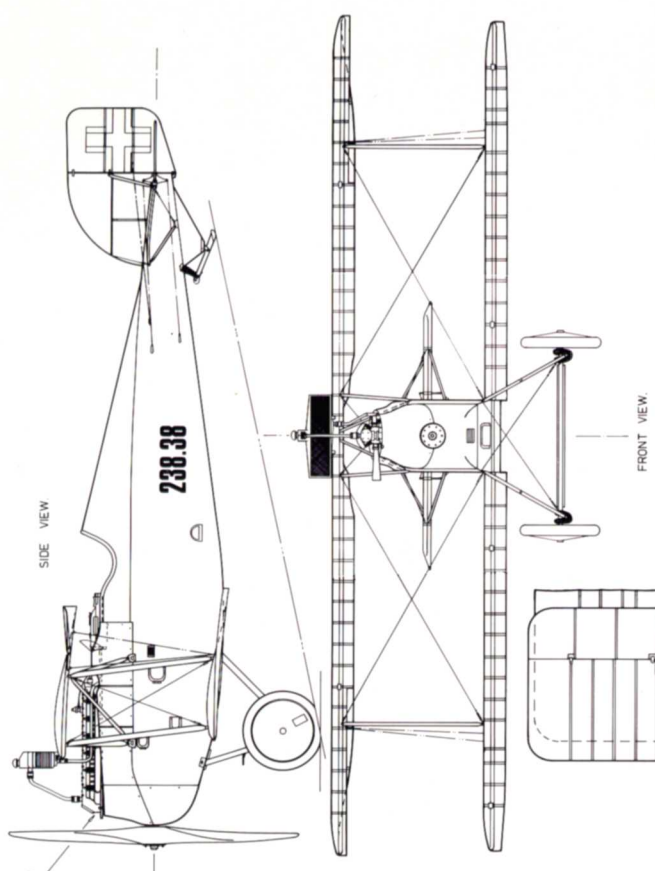

Blast tubes braced to 160 HP Austro-Daimler.

FRONT VIEW.

238.38 BUILT BY AVIATIK & FITTED WITH WING MOUNTED RADATOR.

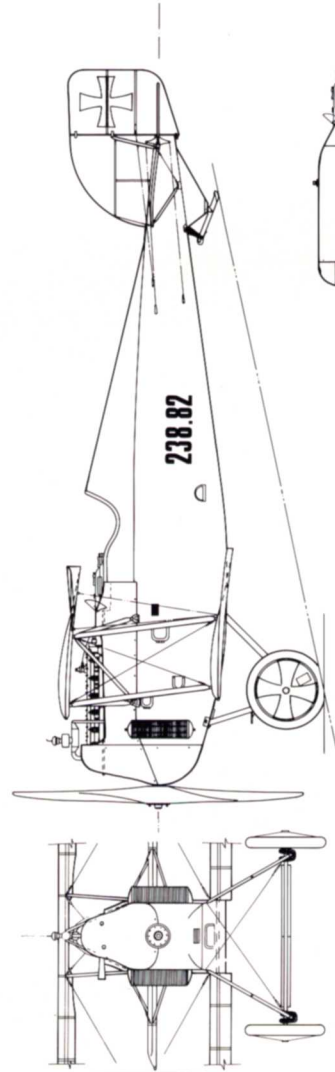

238.82 BUILT BY AVIATIK & FITTED WITH SIDE RADATORS

Wings with close spaced ribs as 238.38.

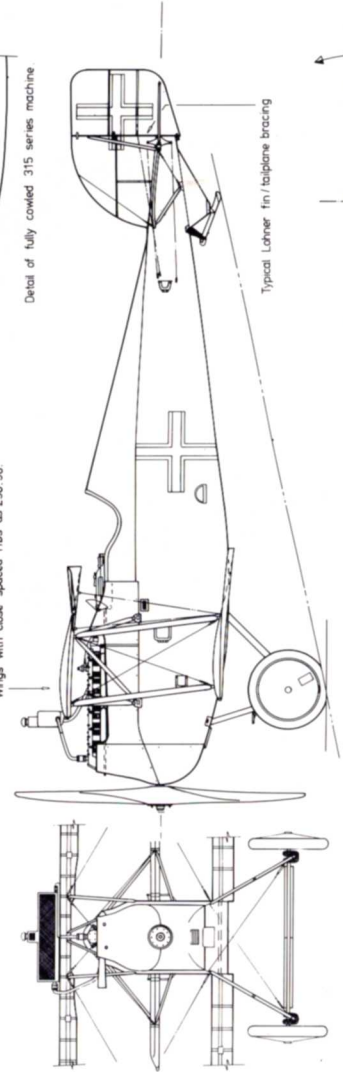

LOHNER SERIES 315 MACHINE

Detail of fully cowled 315 series machine

Typical Lohner fin / tailplane bracing

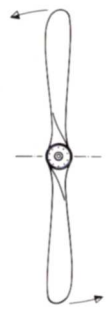

Propeller detail.

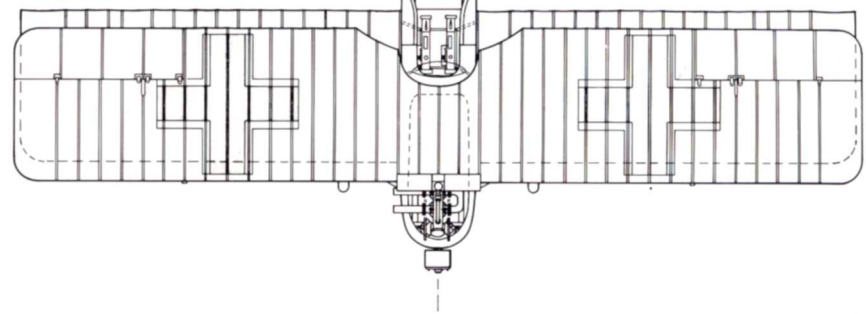

PLAN VIEW.

The help and guidance given by the following gratefully acknowledged :-
Peter M. Grosz
George Haddock
Ian R. Slair
Bernd Totschinger.



Fuselage sections

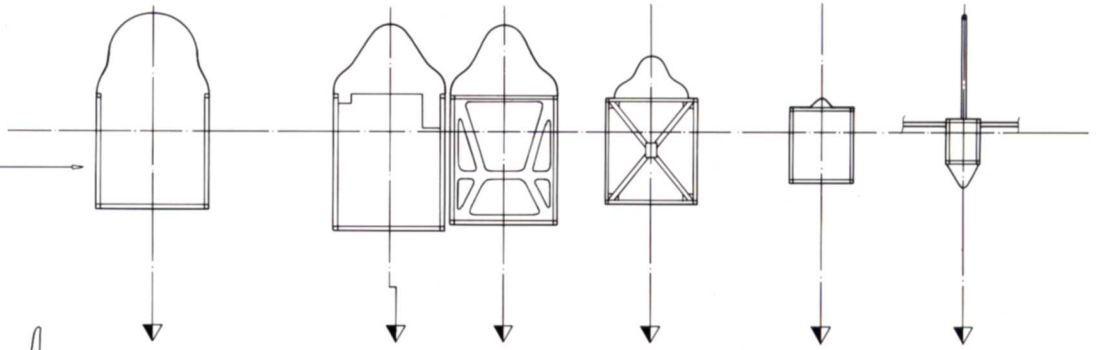

Glazed panels in forward decking to illuminate dashboard.

138.27

Hinged access covers, open at rear, sizes shapes & positions vary.

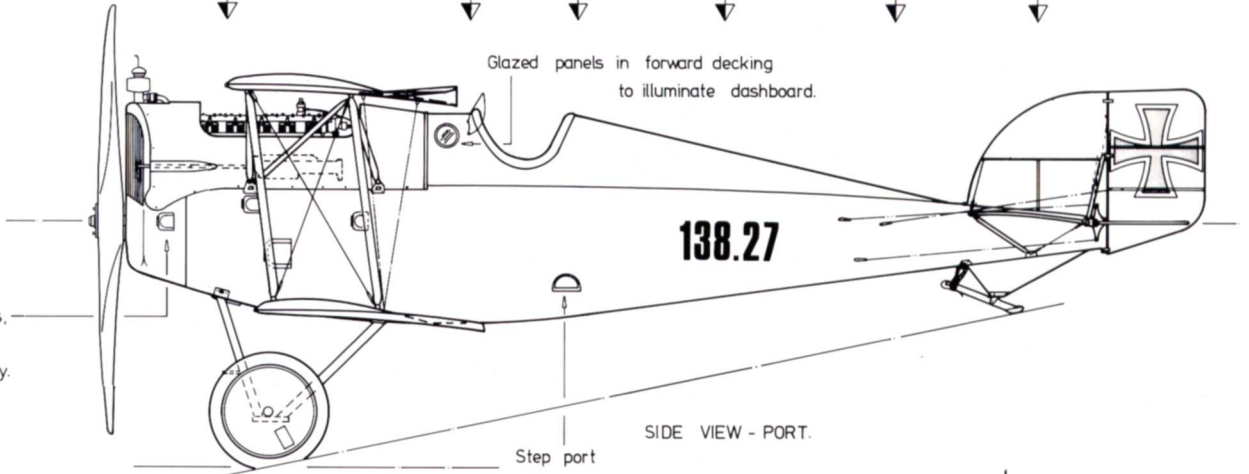

SIDE VIEW - PORT.

Step port side only.

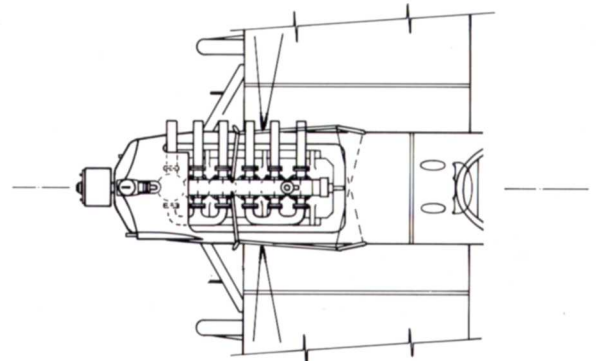

PLAN TOP WING REMOVED.

PLAN VIEW.

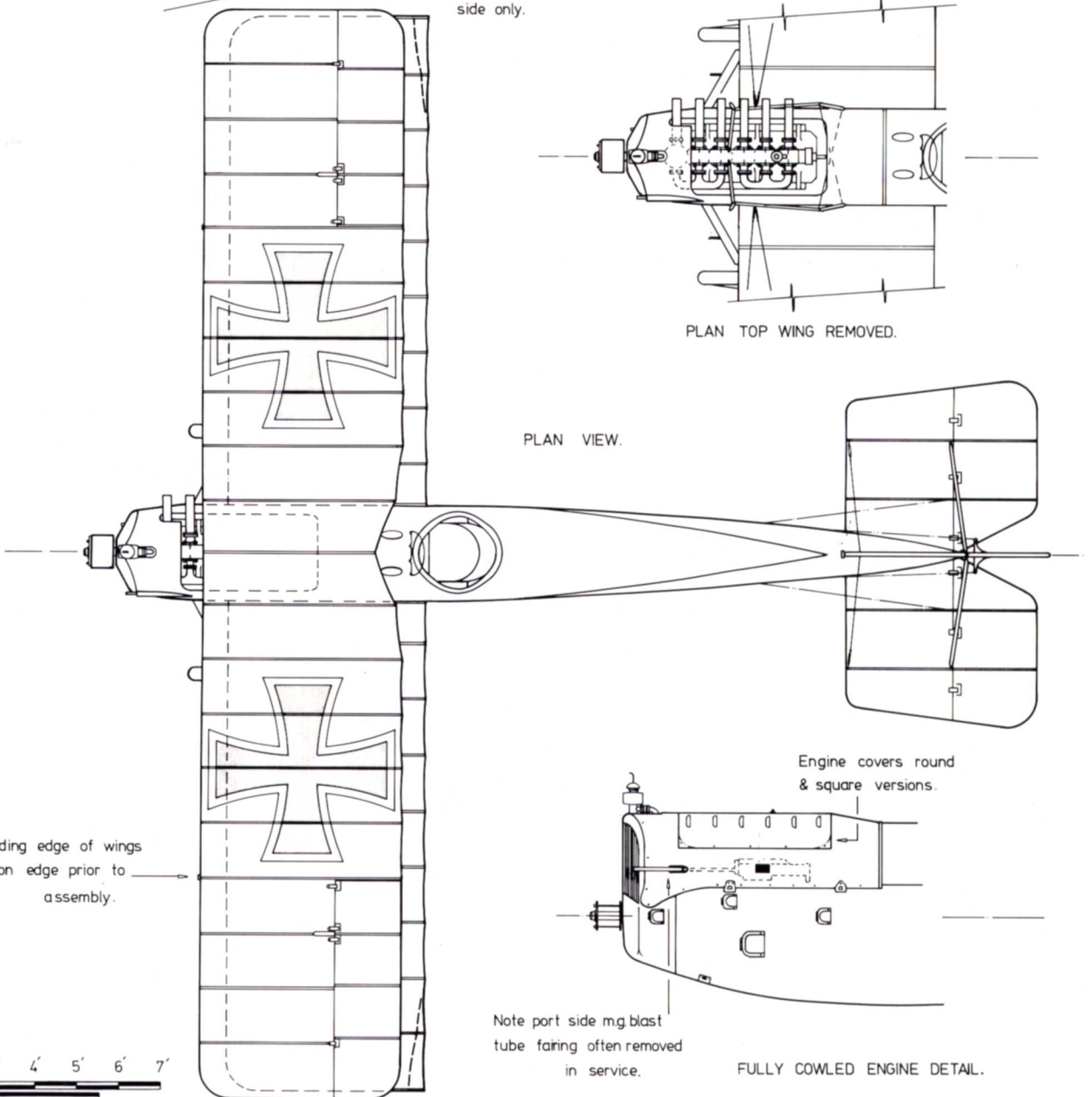

Pads fitted to leading edge of wings to allow stacking on edge prior to assembly.

Engine covers round & square versions.

Note port side mg blast tube faring often removed in service.

FULLY COWLED ENGINE DETAIL.

16

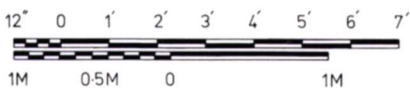

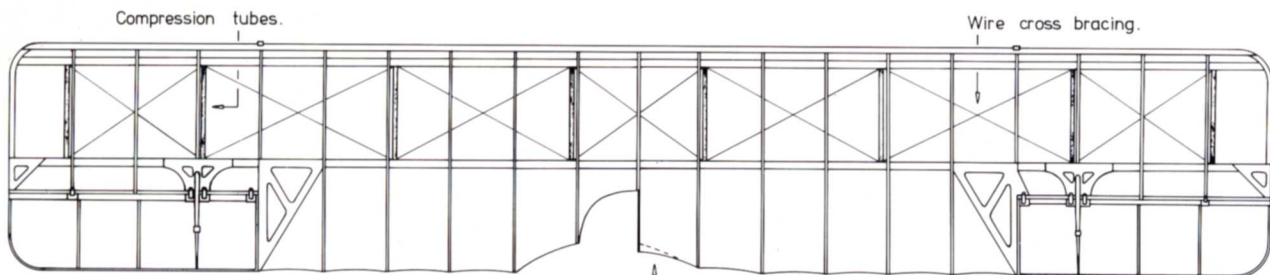

UPPER WING STRUCTURE

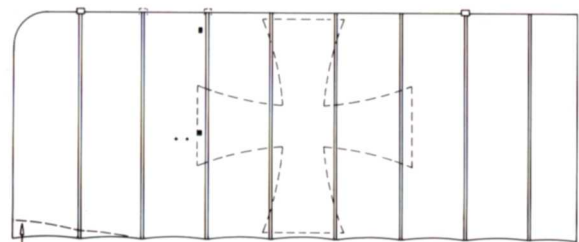

LOWER WING PLAN

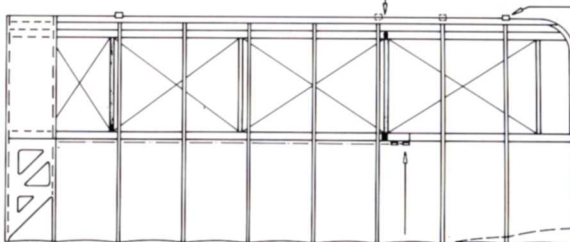

LOWER WING STRUCTURE

Aileron control cable pulleys.

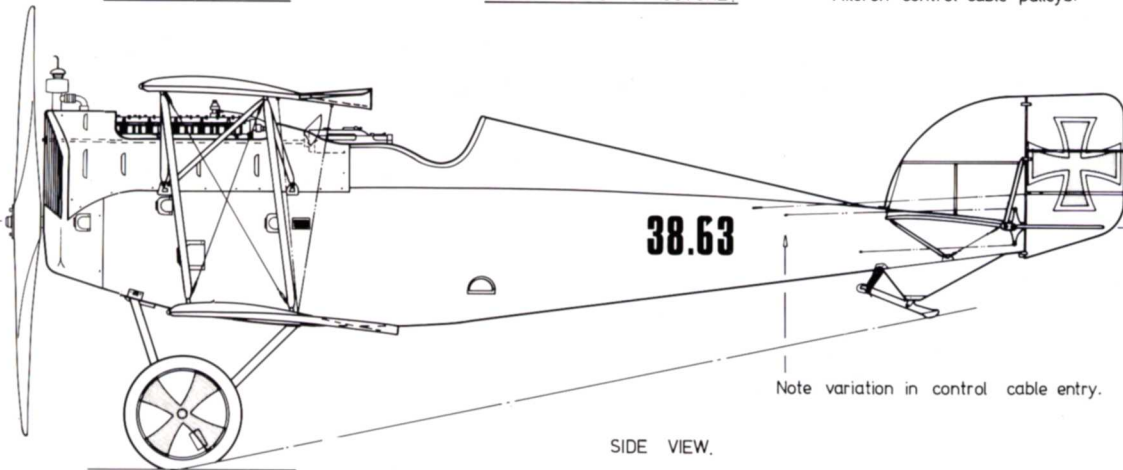
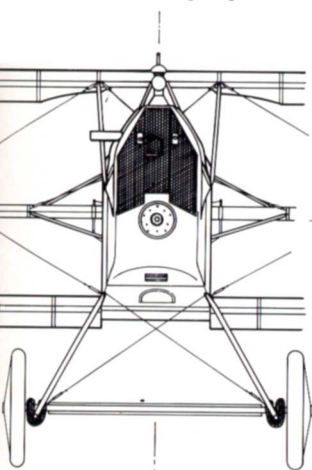

AVIATIK D.I FITTED WITH M.G.'S
IN FRONT OF COCKPIT

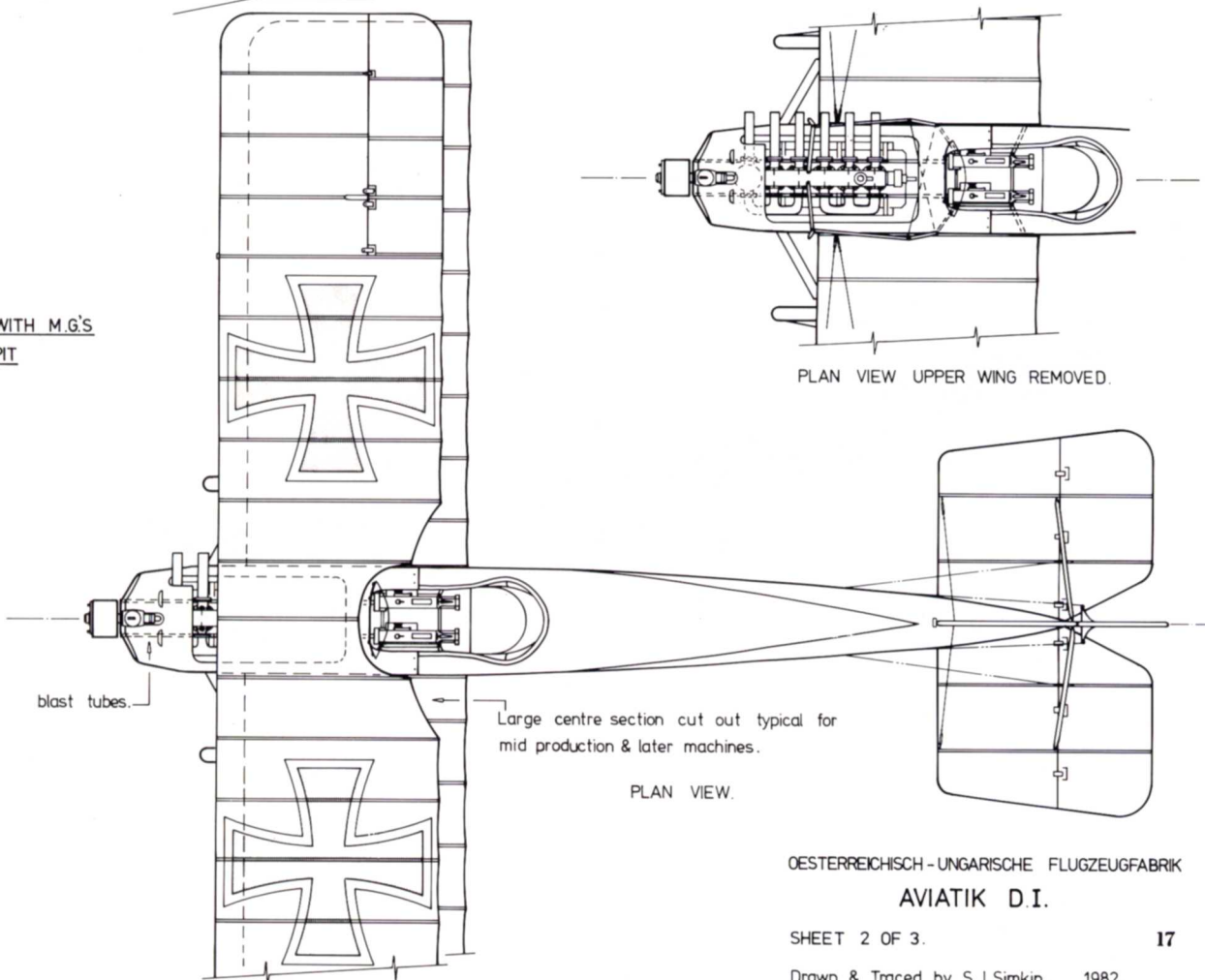
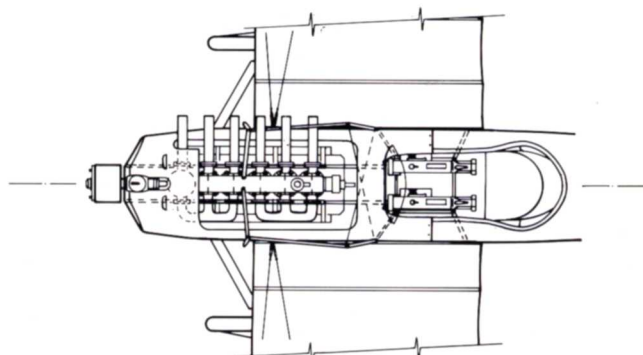

OESTERREICHISCH-UNGARISCHE FLUGZEUGFABRIK
AVIATIK D.I.

For wing details see 38.63 sheet 2.

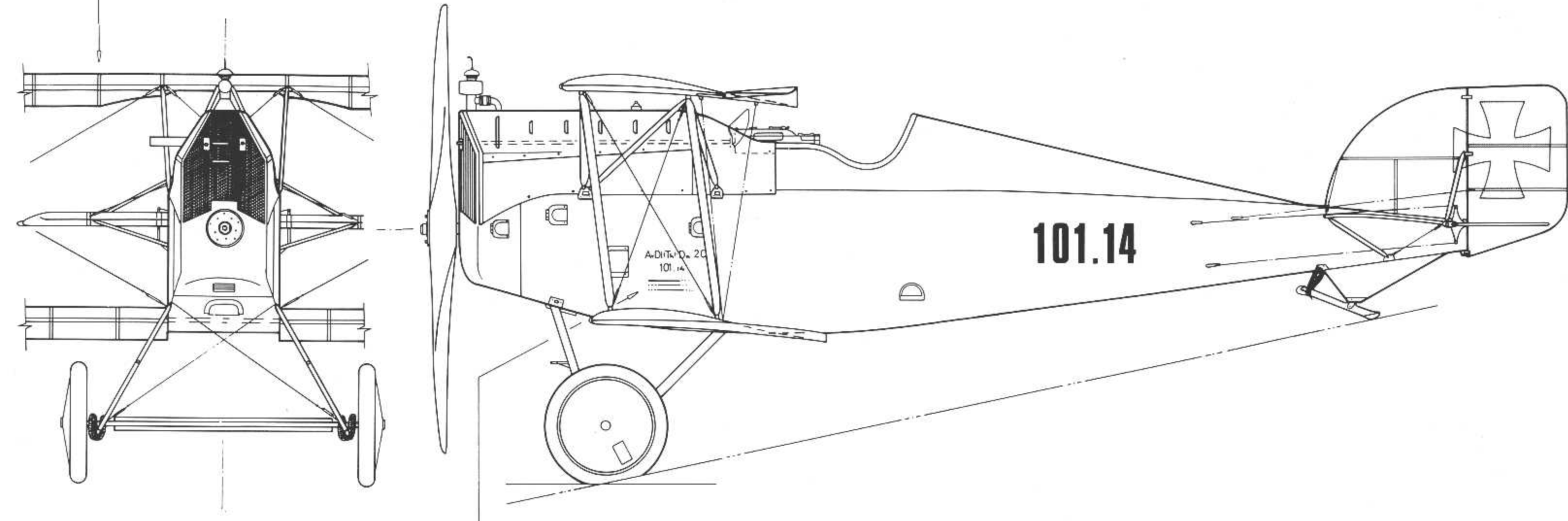

A.D.I. (T.)-D. 200
101.14
LEERGEWICHT 530
MAX. BETRIEBSSTOFF 118
MAX. NUTZLAST 130

101.14 BUILT BY THÖNE & FIALA.

Blast tubes braced to
160 H.P. Austo Daimler.

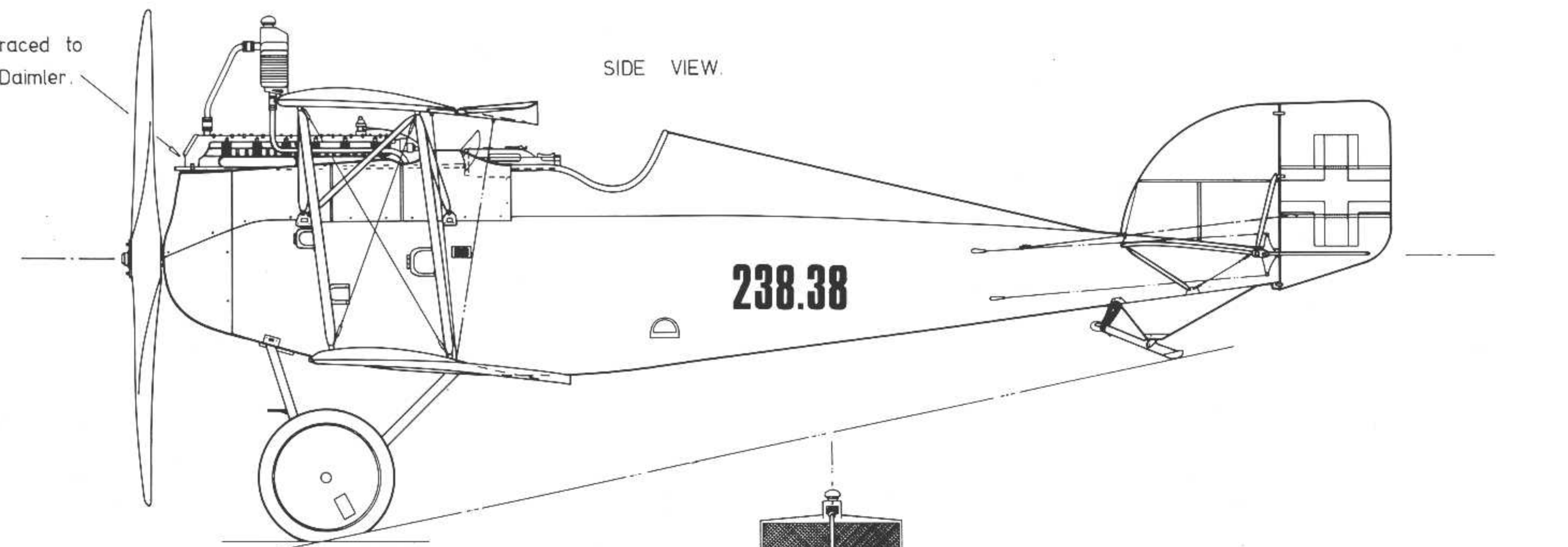

SIDE VIEW.

238.38

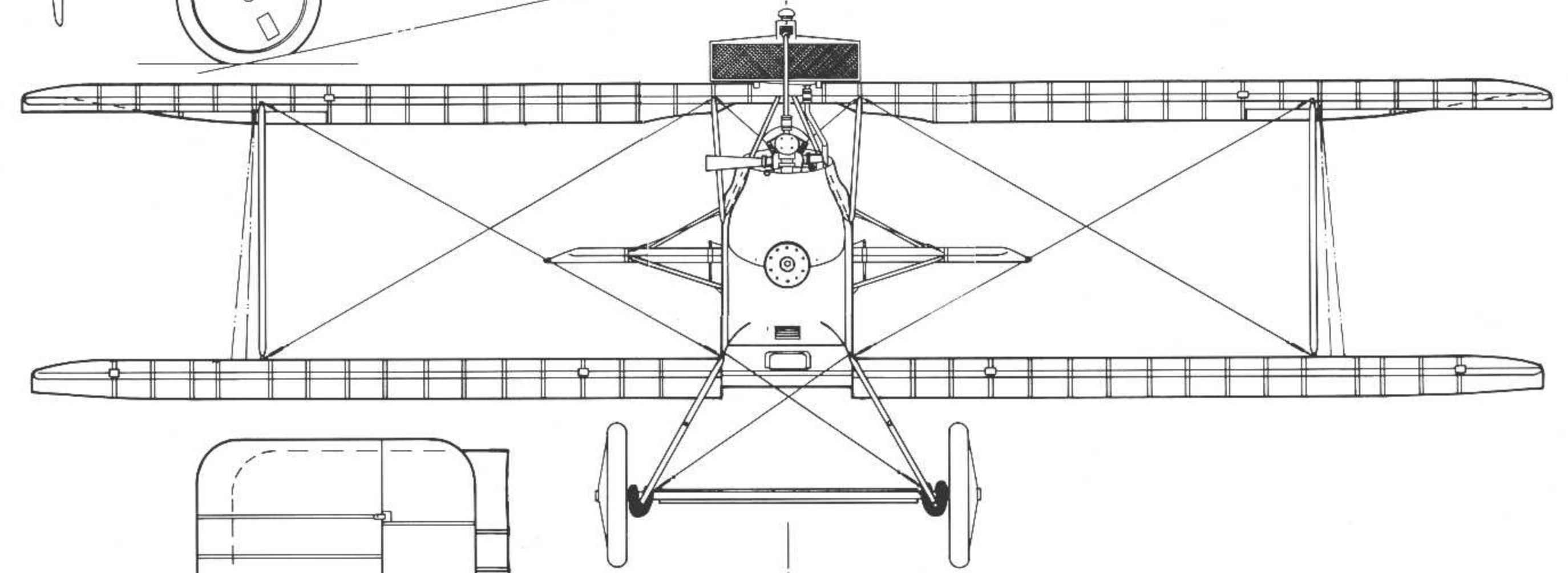

FRONT VIEW.

238.38 BUILT BY AVIATIK & FITTED
WITH WING MOUNTED RADIATOR.

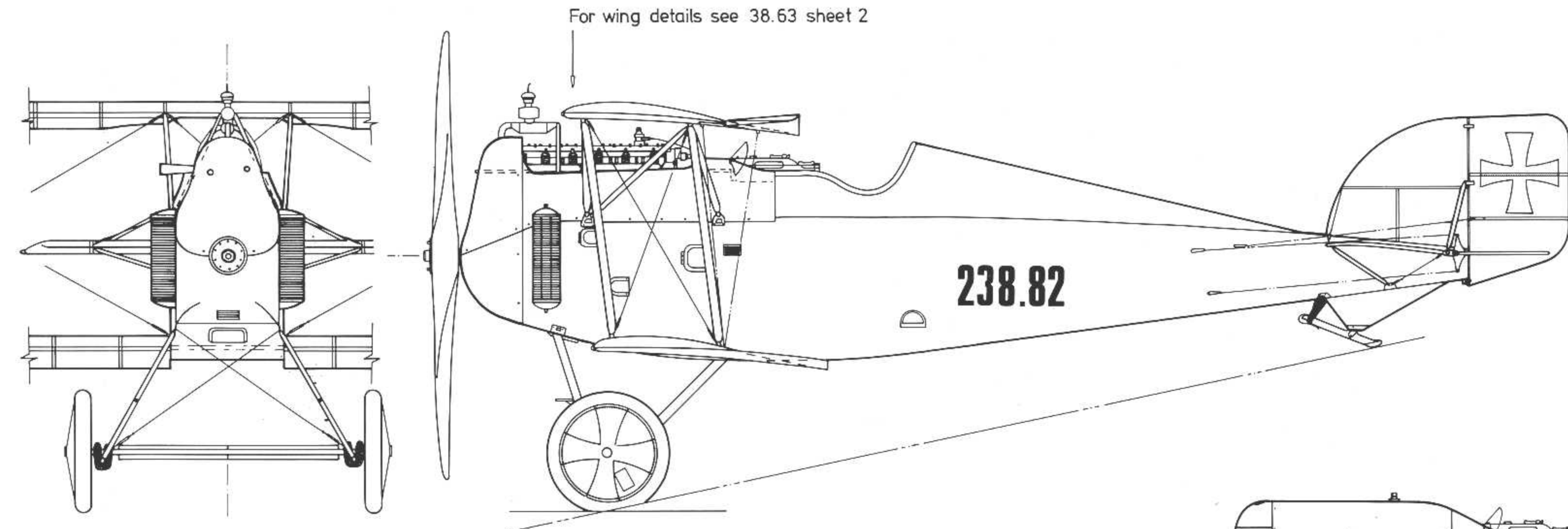

For wing details see 38.63 sheet 2

238.82 BUILT BY AVIATIK & FITTED WITH
SIDE RADIATORS.

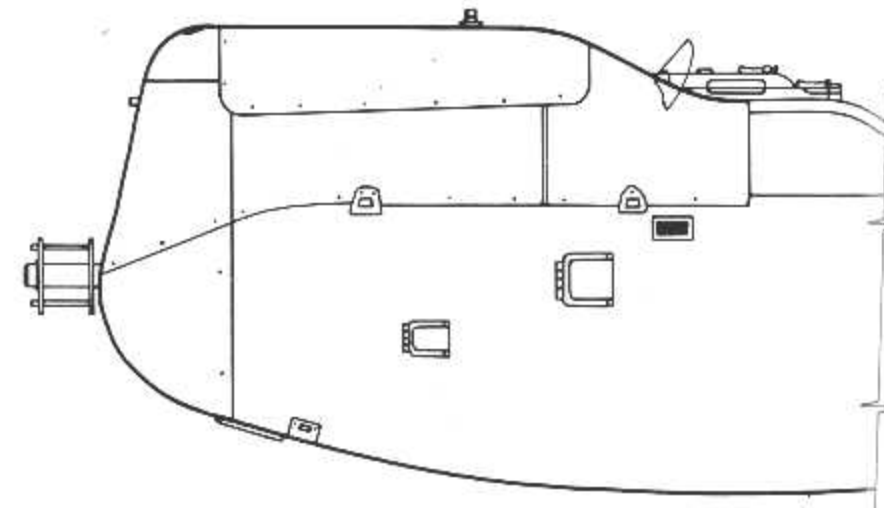

Detail of fully cowled 315 series machine.

Wings with close spaced ribs as 238.38.

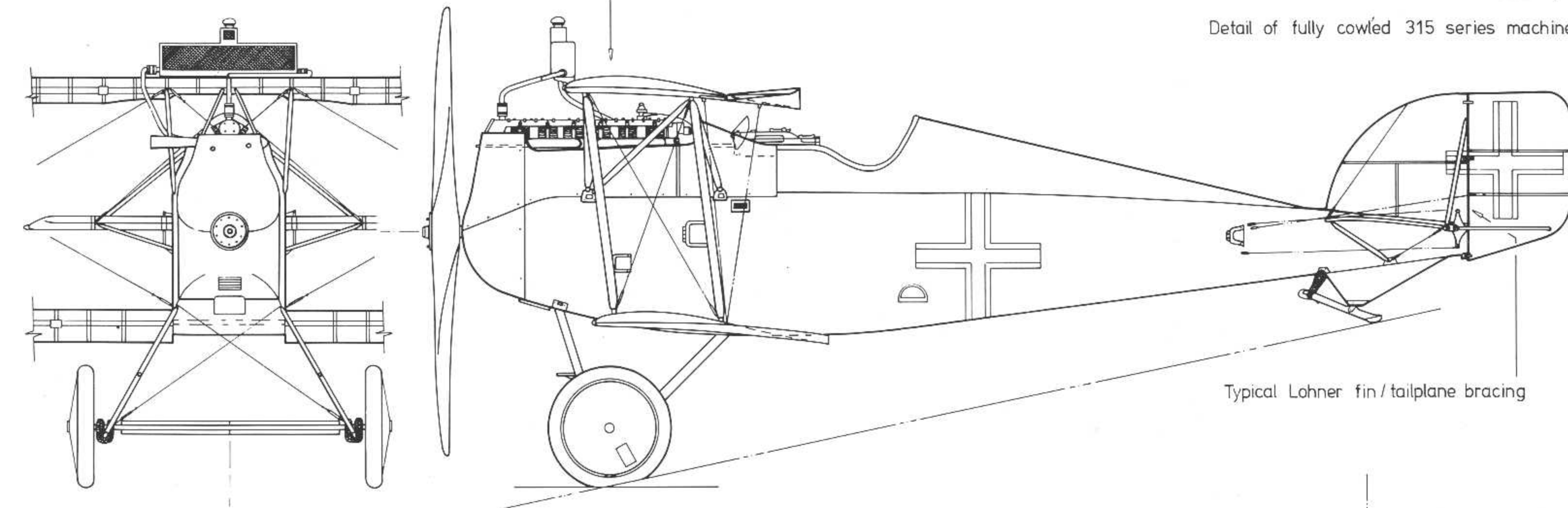

Typical Lohner fin / tailplane bracing

LOHNER SERIES 315 MACHINE

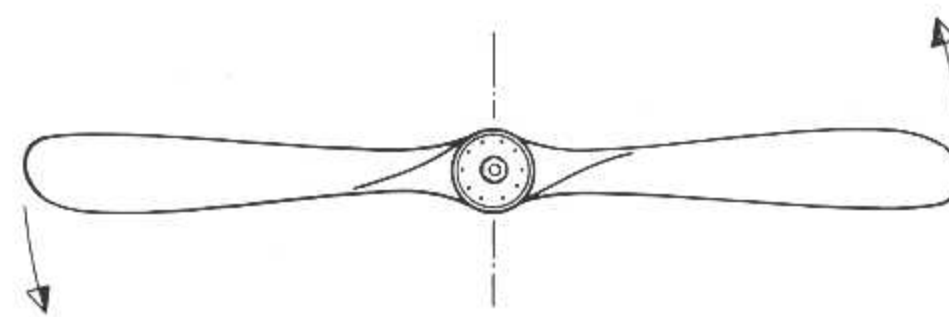

Propeller detail.

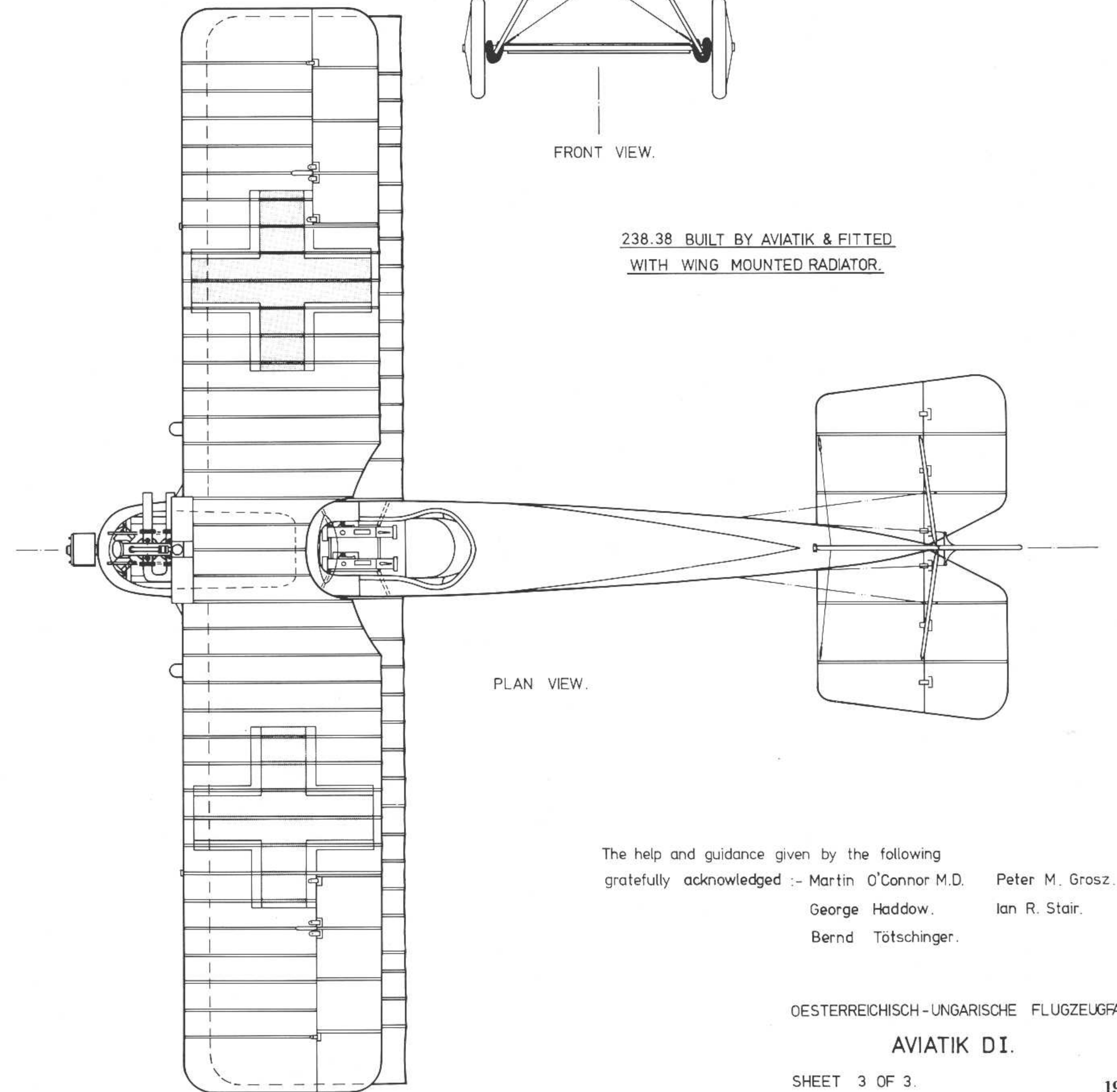

PLAN VIEW.

The help and guidance given by the following
gratefully acknowledged :- Martin O'Connor M.D. Peter M. Grosz.
George Haddow. Ian R. Stair.
Bernd Tötschinger.

OESTERREICHISCH-UNGARISCHE FLUGZEUGFABRIK

AVIATIK D.I.

SHEET 3 OF 3.

19

Drawn & Traced by S.J.Simkin. 1982.

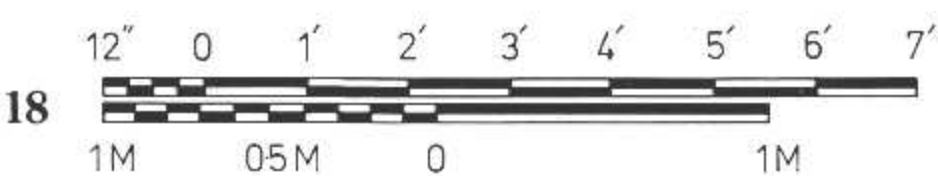

200 HP Austro Daimler.

Fin, rudder & tailplane - steel tube.

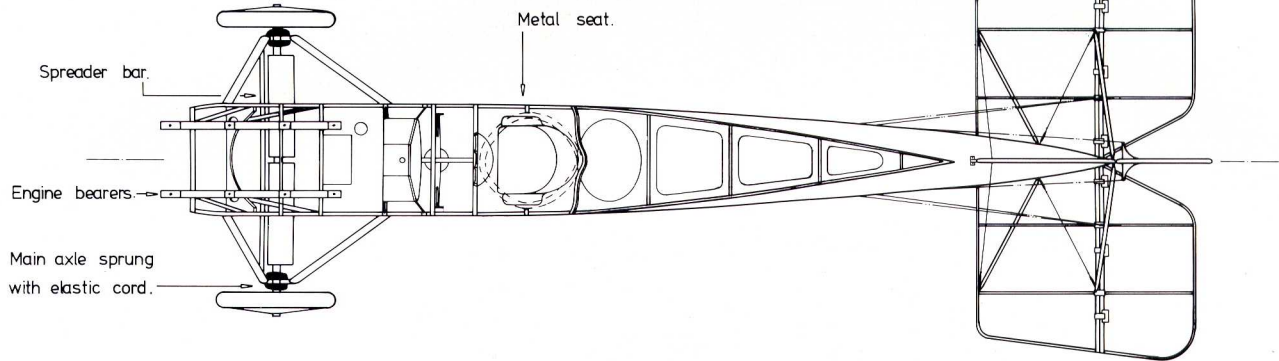
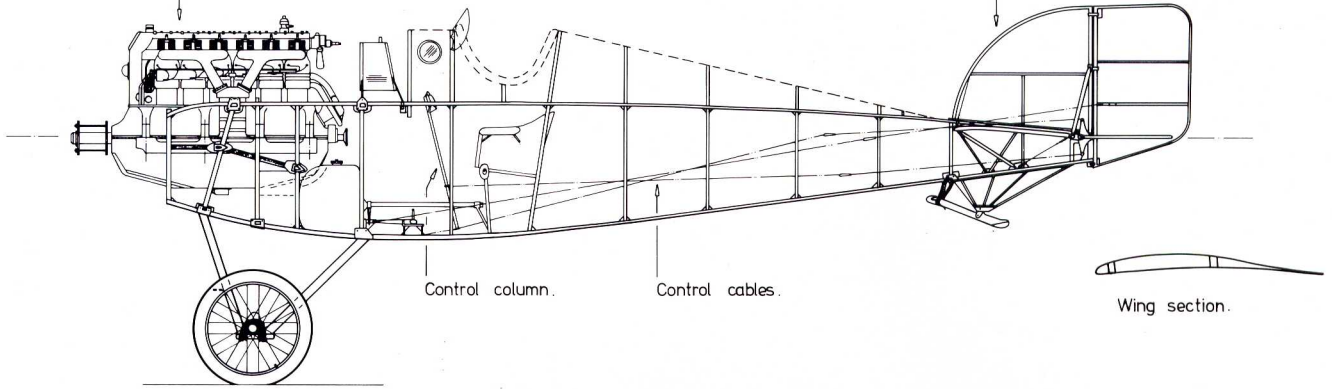

STRUCTURAL DETAILS OF MAIN PRODUCTION
VERSION BASED ON MACHINE 138.27.

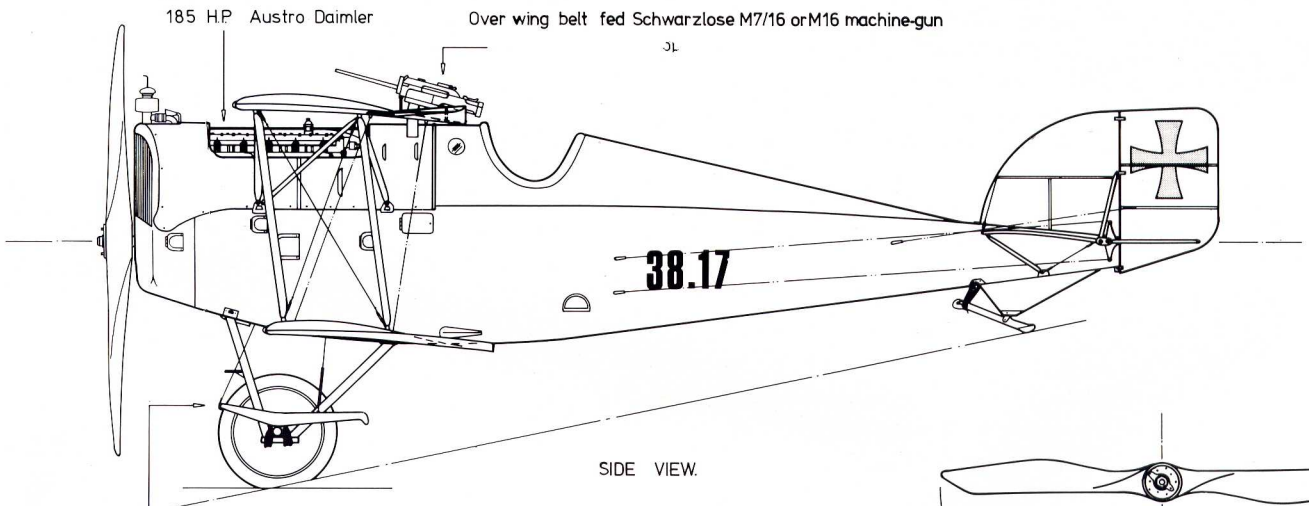

Claw brake, note near side wheel & struts omitted for clarity.

EARLY PRODUCTION MACHINE.

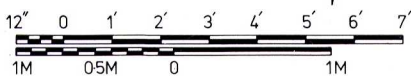
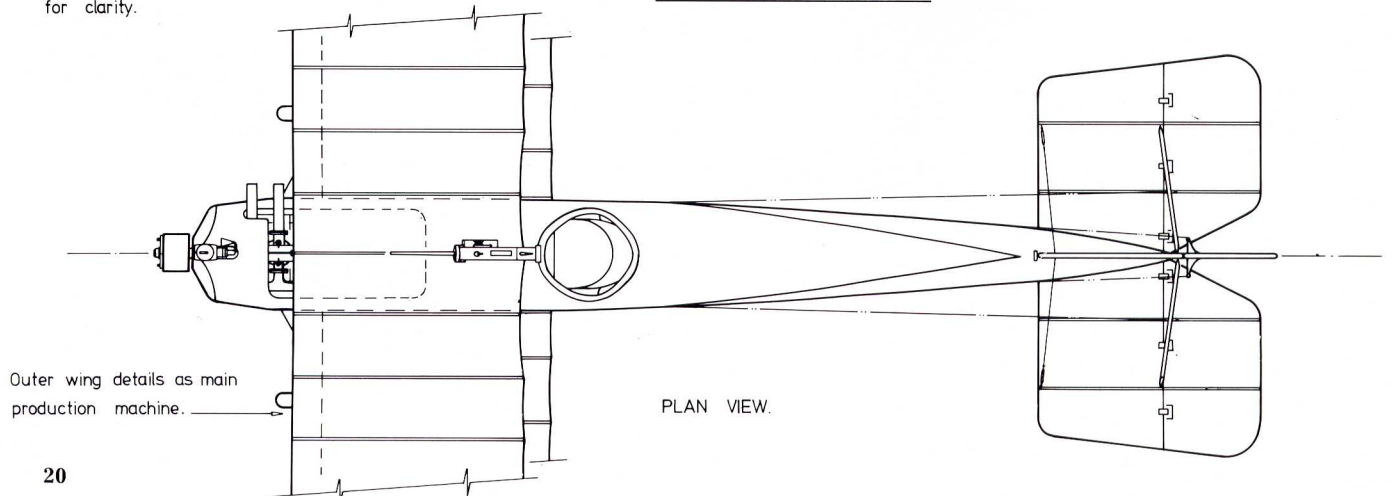

General note - seven configurations of the Aviatik DI are shown on sheets 1,2 & 3 however many detail variations of each type existed. Also machines in a production series rarely had a common configuration,

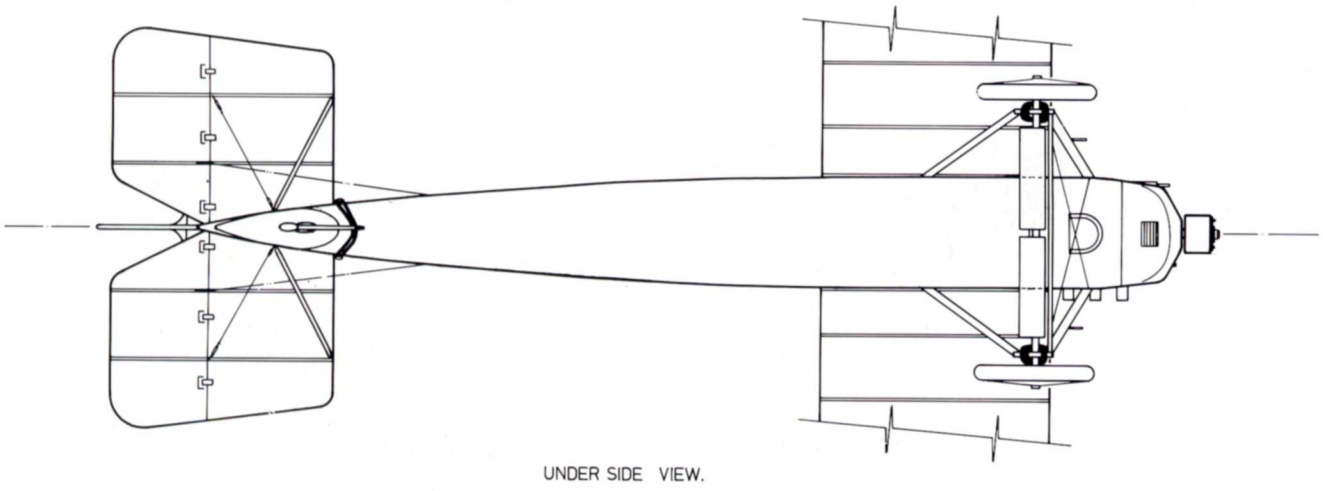
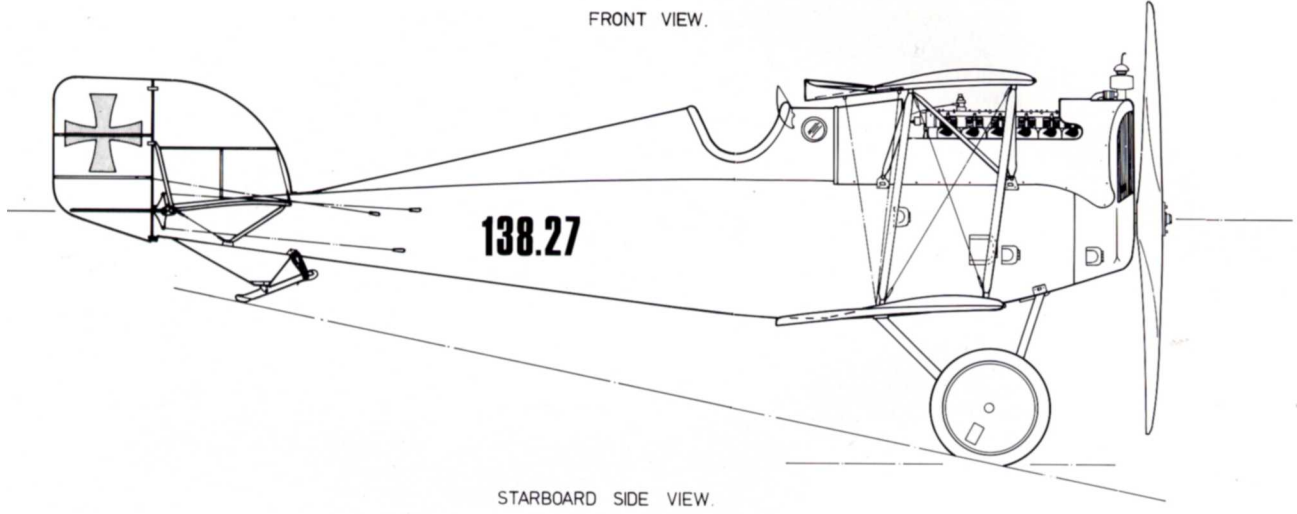
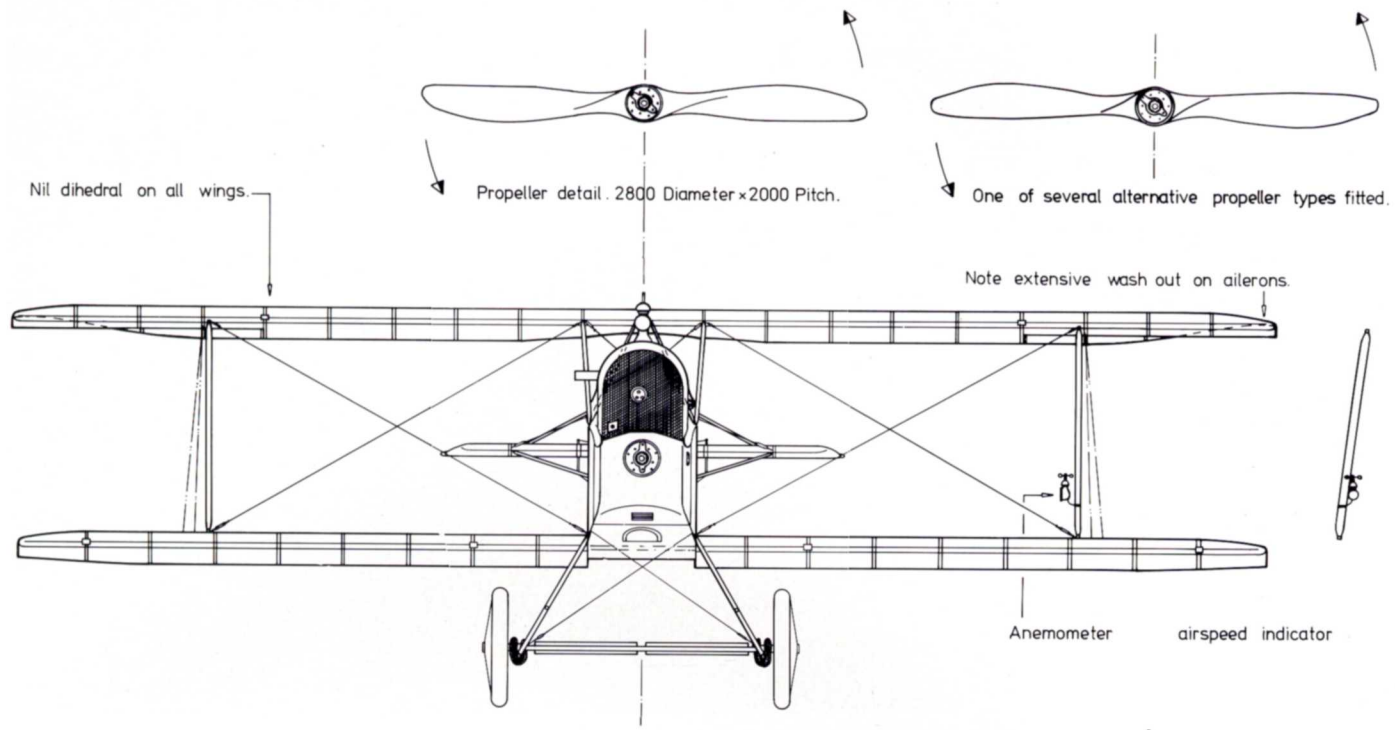

AVIATIK DI FITTED WITH ROUNDED RADIATOR AND M.G.'S MOUNTED ALONG SIDE THE ENGINE.

OESTERREICHISCH - UNGARISCHE FLUGZEUGFABRIK

AVIATIK D.I

SHEET 1 OF 3.

21

Drawn & Traced by S.J. Simkin. 1982.

THE AVIATIK D.I IN DETAIL

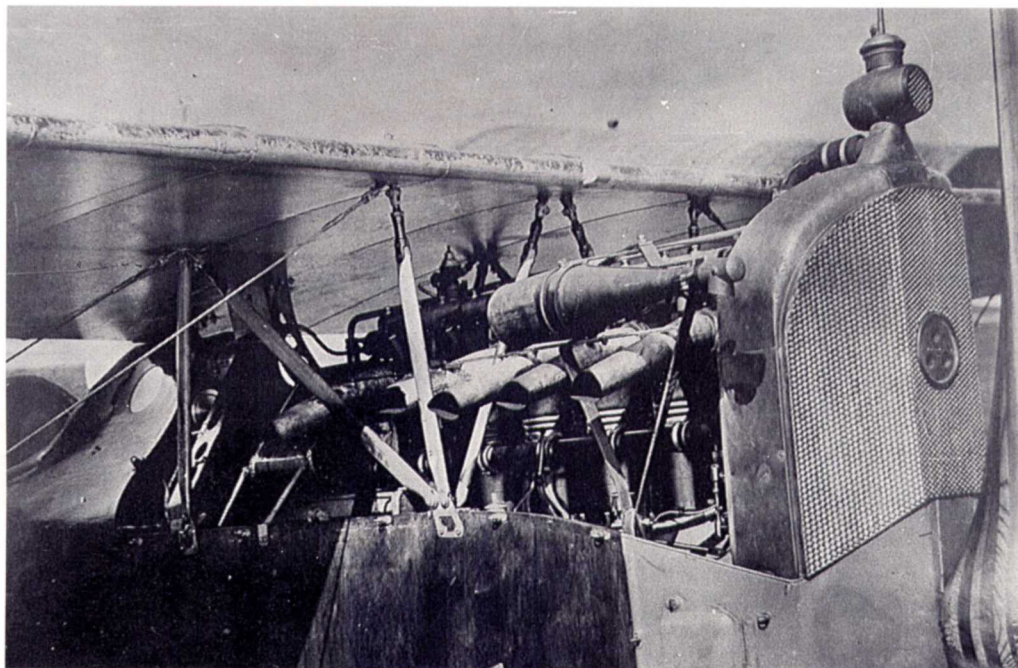

▲33

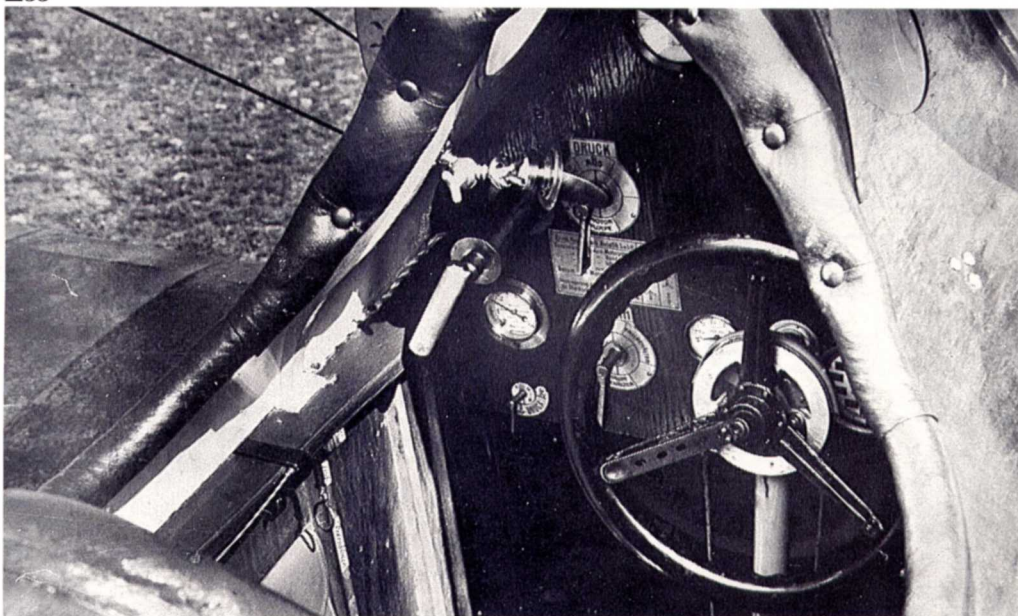

▲34 ▼35

33. The *Sottoscope* shown here mounted on Aviatik D.I 38.06 provided the pilot with a view of the terrain below when operating as a single-seat reconnaissance fighter. The camera, installed behind the pilot's seat, was actuated by remote control.

34. Close-up of the pilot's cockpit in Aviatik D.I 38.06, an early production example. In later machines, the wheel control was replaced by a stick control. Two circular windows on each side of the cockpit illuminated the instrument panel.

35 and 36. An unarmed Aviatik D.I was used to evaluate a periscope for aiming the guns. The periscope screen and the mounting brackets for the over-the-wing machine gun are clearly in evidence.

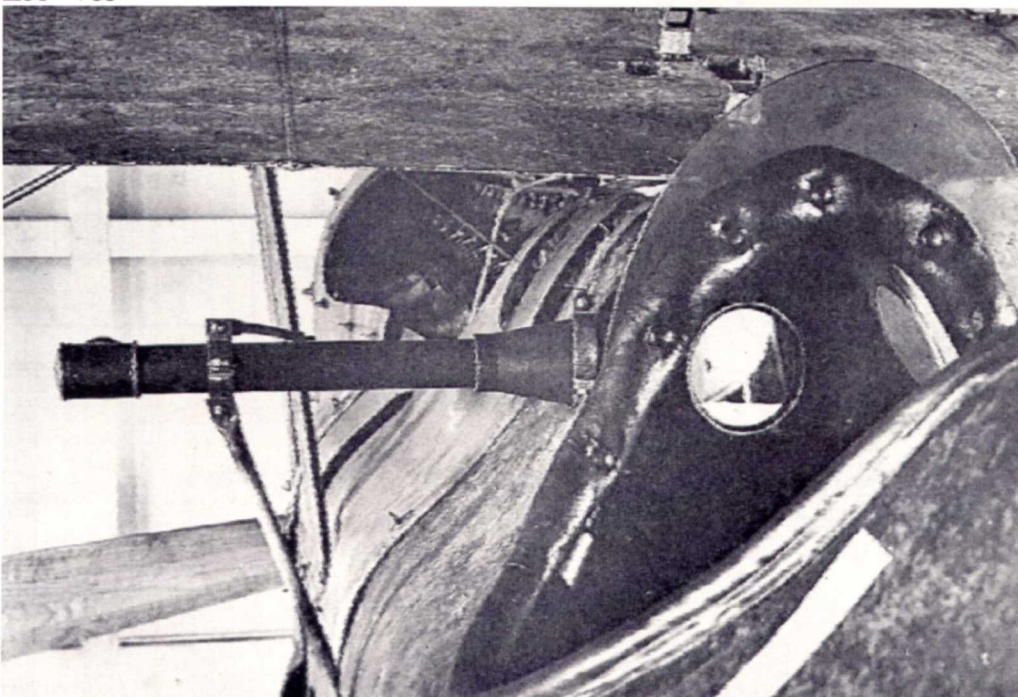

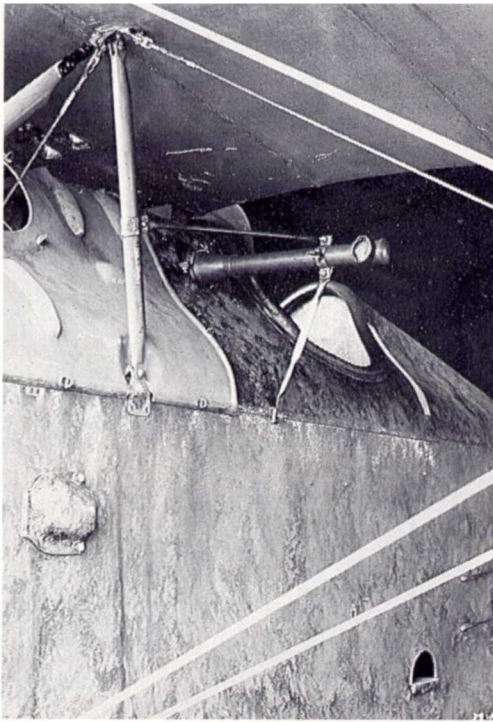

▲36

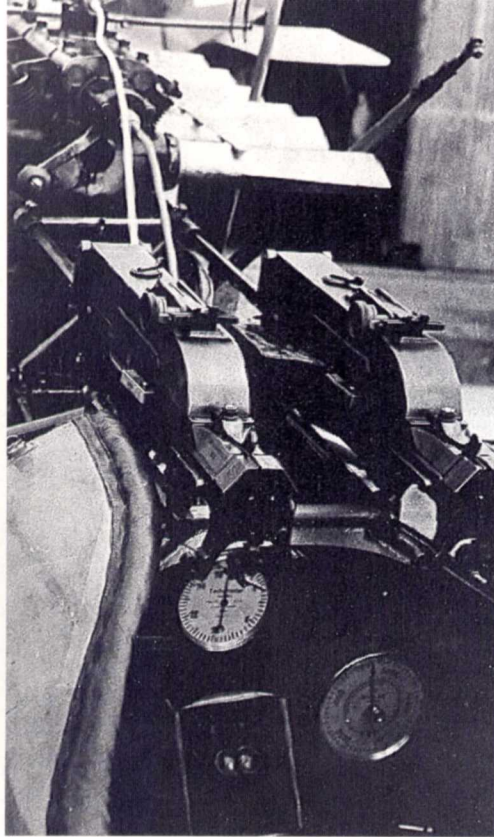

▲37

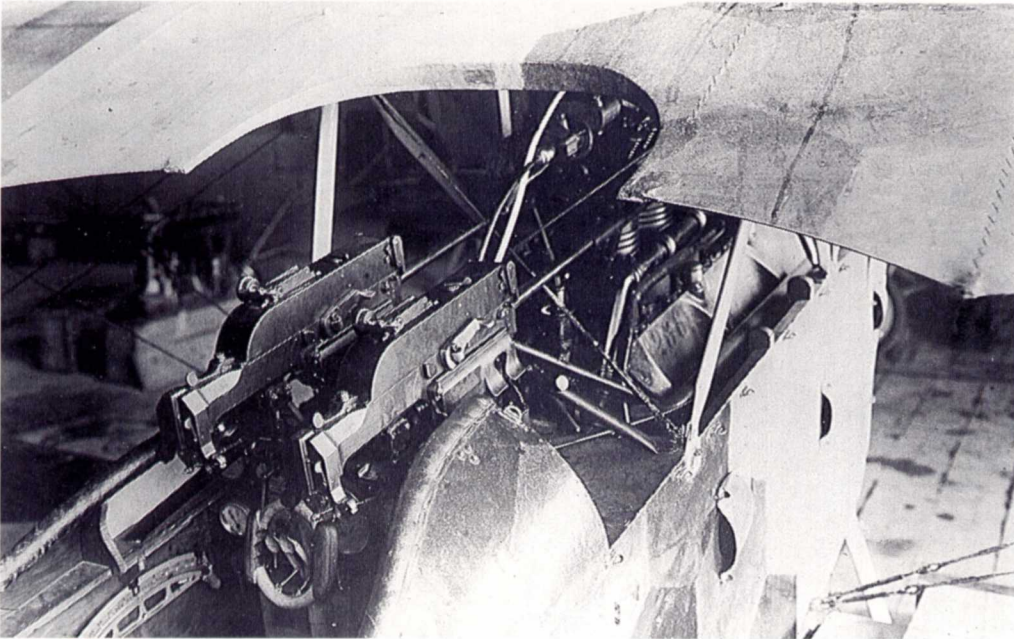

▲38 ▼39

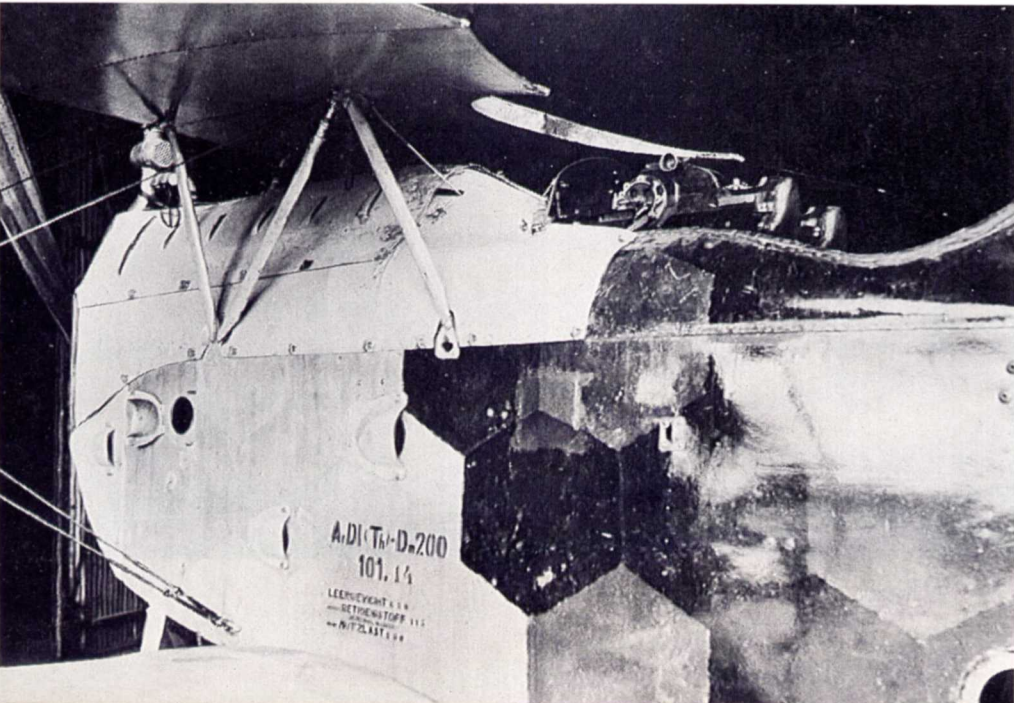

37. Twin Schwarzlose M 16 machine guns mounted in a late-model Aviatik D.I. Owing to engine height, the pilot had to lean to one side to aim the guns. Blast tubes protected the engine from damage.

38. A Thöne & Fiala-built Aviatik D.I 101.14 with accessible Schwarzlose M 16 machine guns. The photograph shows the firing triggers inside the control stick grip and the inclinometer mounted on the port side of the cockpit.

39. Aviatik D.I(Th) 101.14. Because of the engine and radiator obstruction, the guns were aimed by leaning out of the cockpit and sighting through a rear and forward sight, the latter is seen mounted forward of the centre-section struts. The style of identification lettering on the fuselage was required on all aircraft and the pattern was similar for all manufacturers.

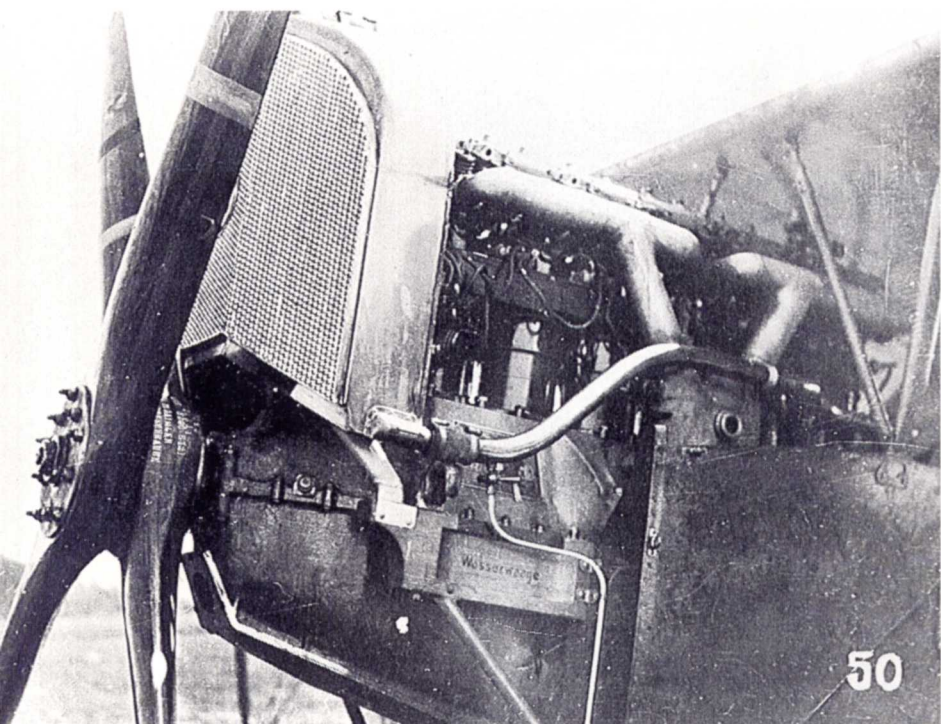

▲40

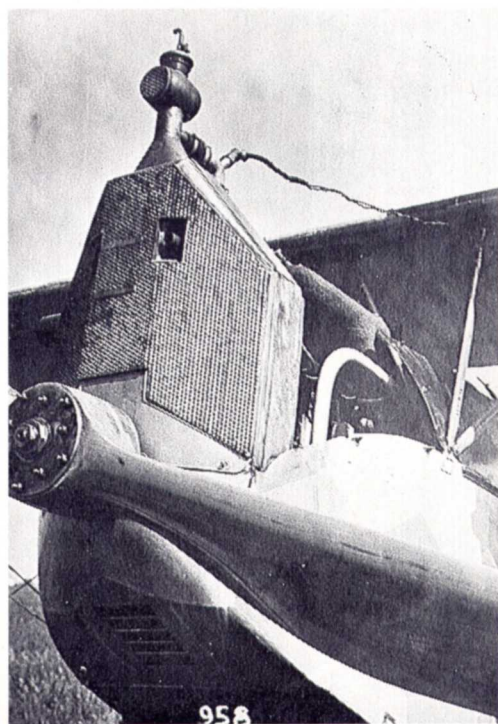

▲41

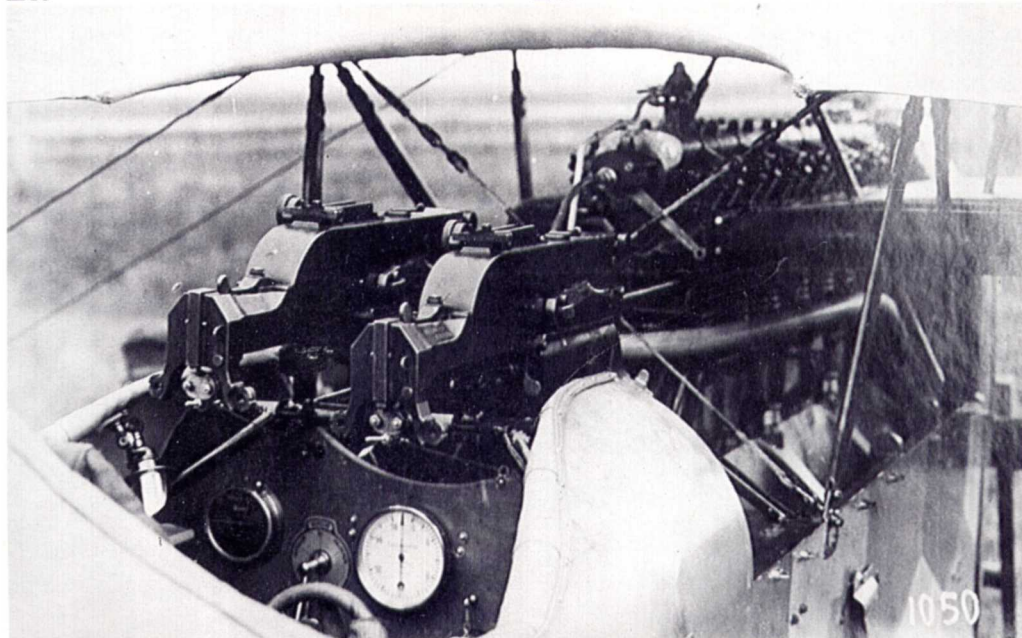

▲42 ▼43

40. The 200 hp Daimler engine and radiator installation in MAG-built Aviatik D.I series 92.

41. Lohner-built Aviatik D.I 115.59 showing a different nose radiator with a rectangular gun aperture.

42 and 43. Lohner-built Aviatik D.I (Lo) 115.70 with twin Schwarzlose M 16 machine guns mounted at eye level, the arrangement preferred by most pilots.

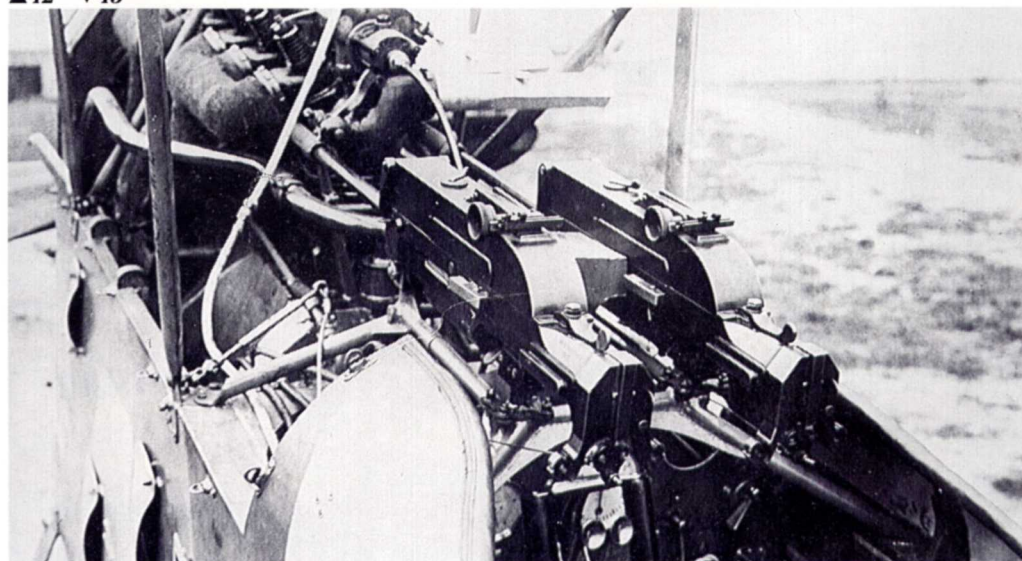

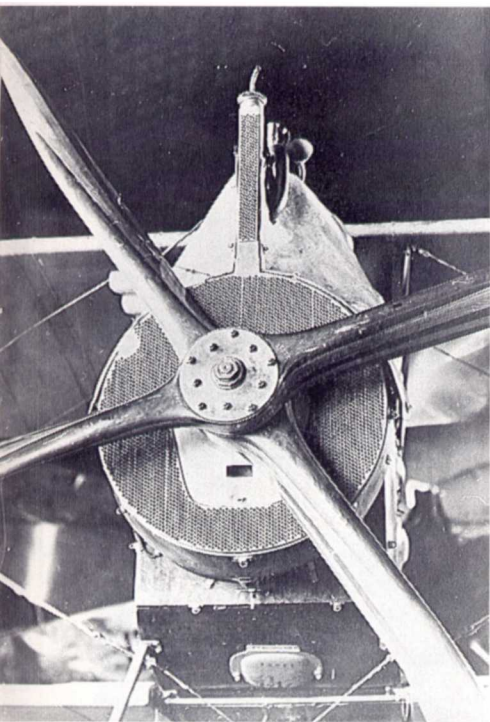

▲44

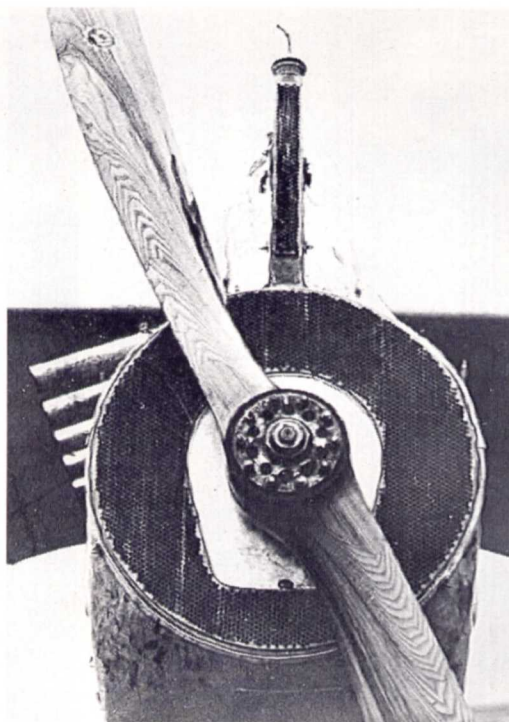

▲45

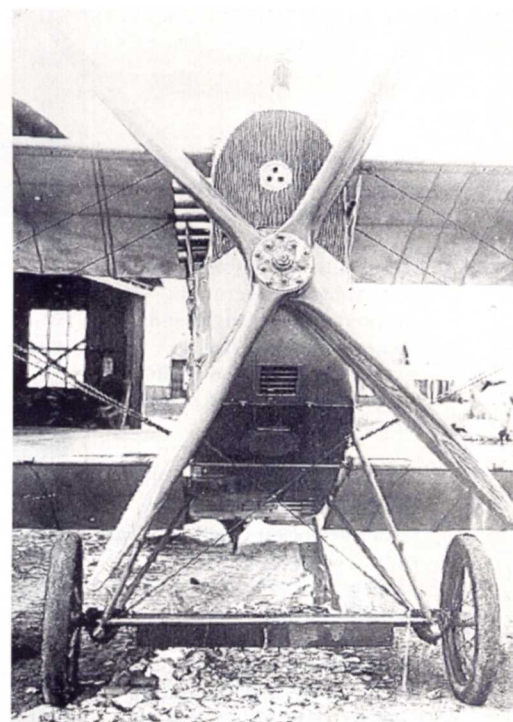

▲46

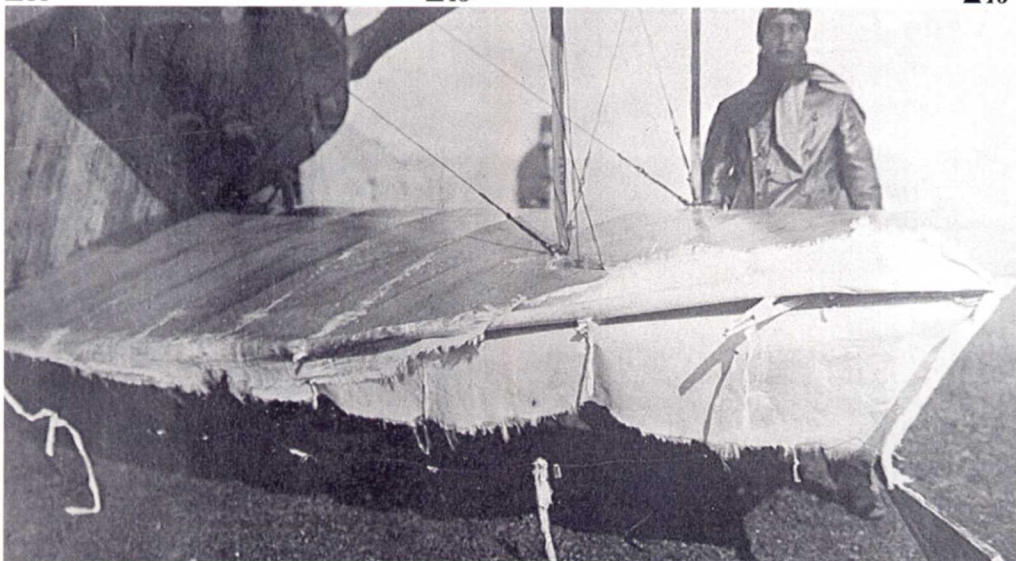

▲47 ▼48

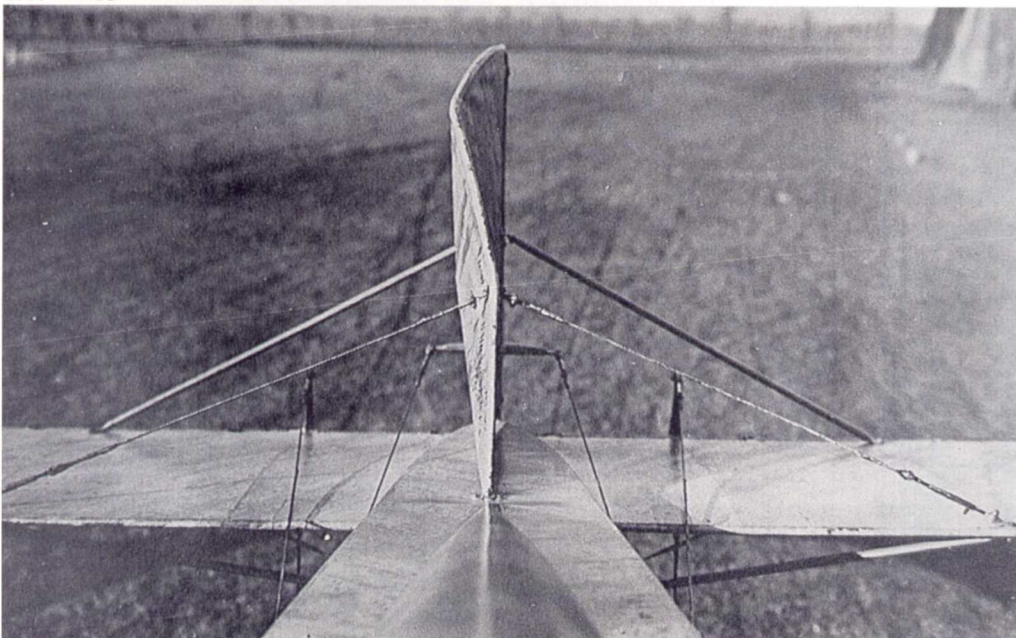

An interesting variety of radiators were employed on Aviatik D.I aircraft, seemingly mounted at random. In addition, many experimental radiator designs were tested in the quest for improving forward visibility. Radiators were manufactured by Erenyi, Weich, Windhoff and Hirschfelder among others.

44. Aviatik D.I 138.11 was flown with an experimental circular radiator in October 1917. The bottom cowling fairing remains to be installed.

45. Another view of Aviatik D.I 138.11, here fitted with a single-bladed airscrew.

46. A standard production machine, Aviatik D.I 138.26, with a rounded nose radiator and four-bladed airscrew.

47. This Aviatik D.I 138.30 suffered massive damage on June 30 1918. The fatigue failure caused by the flexing trailing edge was generally caused by violent manoeuvres and often faulty construction and poor materials.

48. As a result of violent manoeuvres, the fin and rudder, a very lightly-built structure, were bent out of shape on Aviatik D.I 138.30 on June 30 1918.

49. Standard production radiator with a single aperture for the starboard gun mounted in an Aviatik D.I series 138 fighter. The four-bladed airscrew is marked with a bright red stripe signifying it is experimental and a white stripe marking it as property of Aviatik.

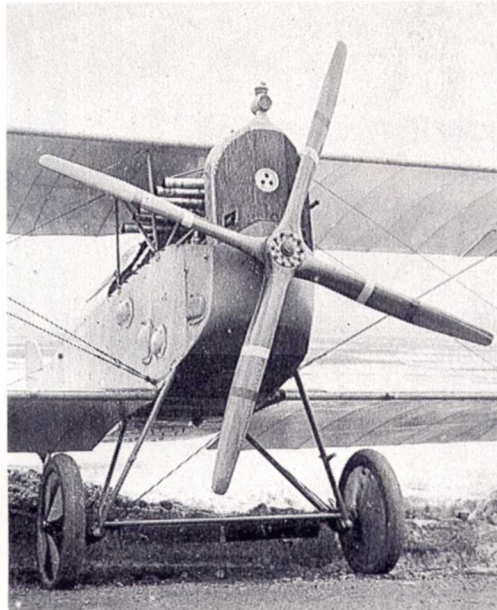

▲49 ▶50

50. Aviatik D.I 138.111 with production radiator fitted with oblong machine gun cut-outs. The projecting extension is an air-cooled condenser unit.

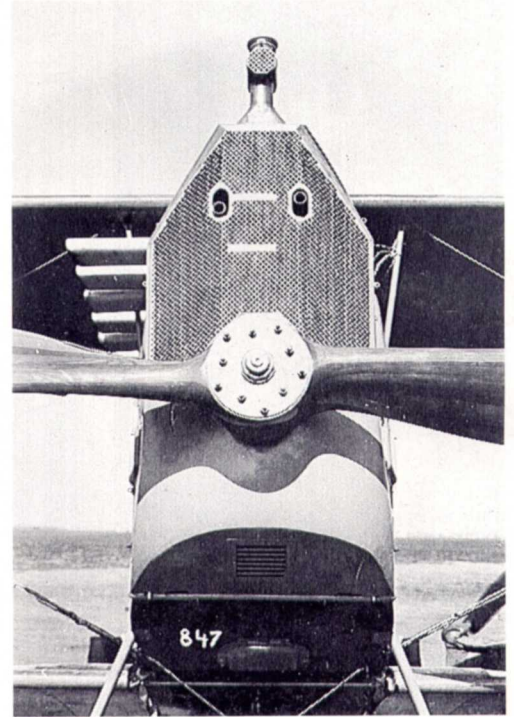

◀51 ▼52

51. Twin side radiators mounted behind the centre-section strut under test on the Aviatik D.I 138.111, fitted with a streamlined condenser tank.

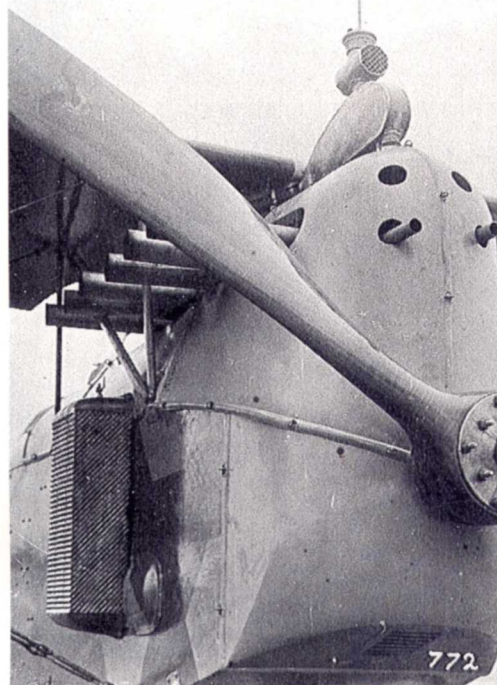

▼53

52. Aviatik D.I with an experimental radiator cut back to provide improved sighting for the raised machine guns. The '5' stencilled on the top wing signifies the proper angle of incidence.

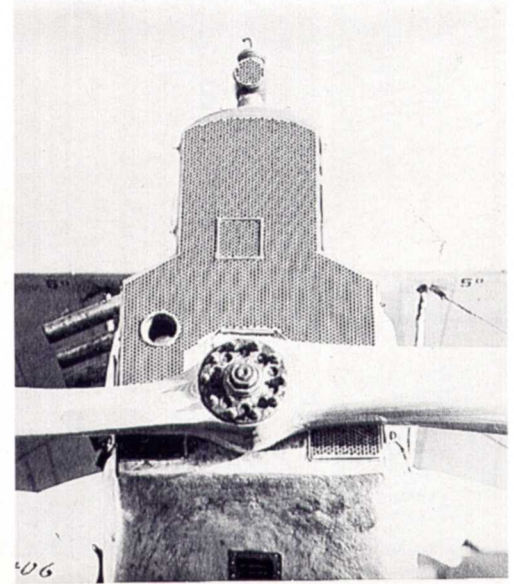

53. Aviatik D.I 138.116 with production radiator showing rectangular cut-outs for twin machine guns mounted at pilot's eye level.

54. Close-up of the 200 hp Daimler engine and condenser assembly on Aviatik D.I 138.16.

▼54

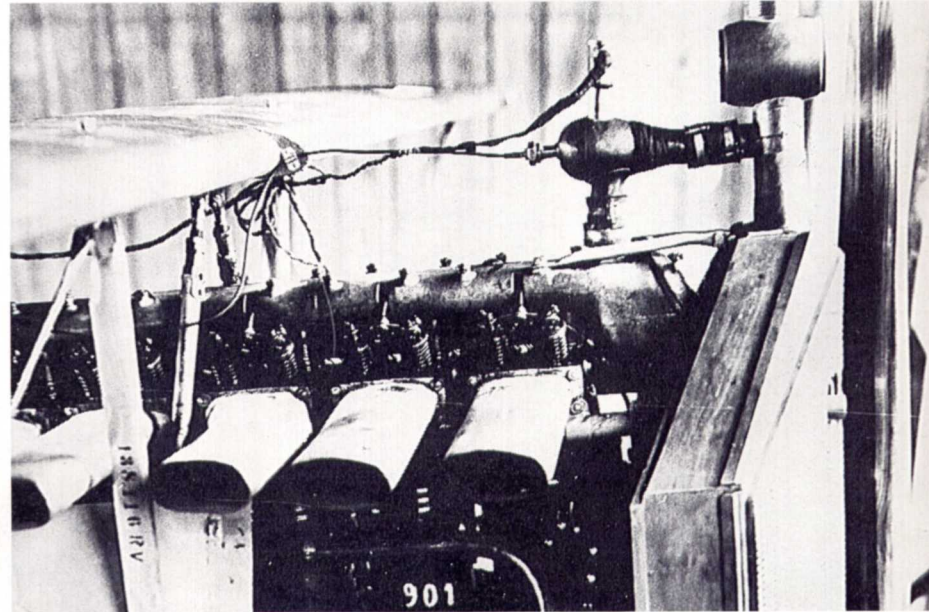
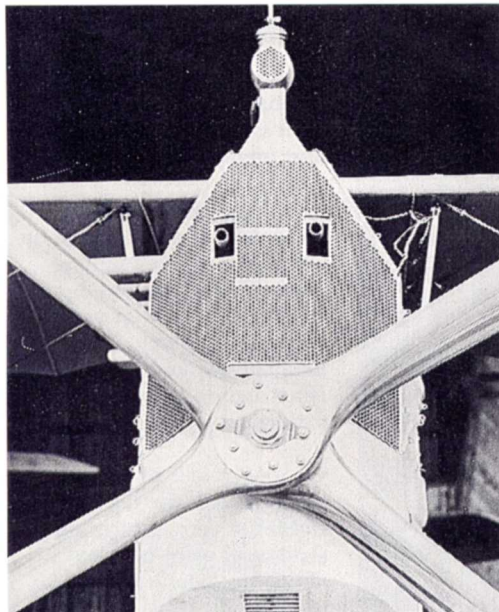

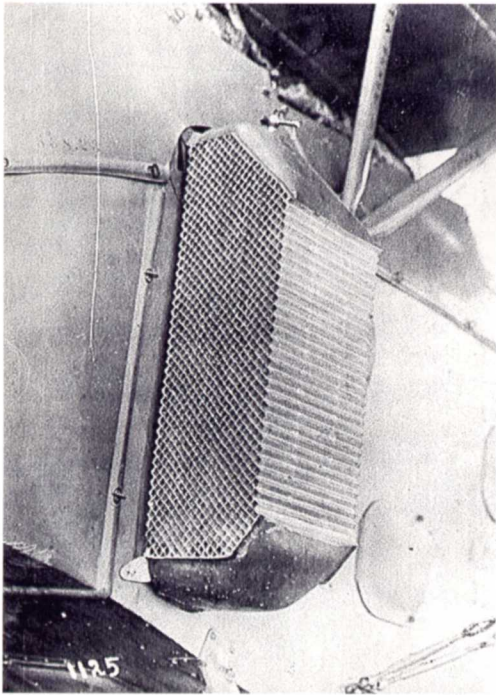

▲55

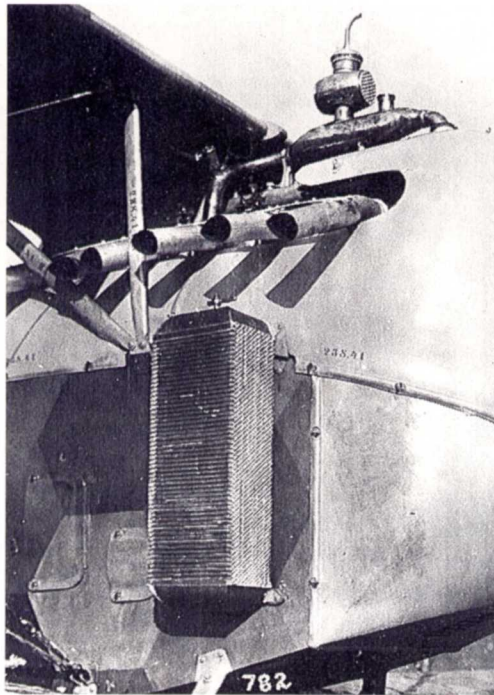

▲56

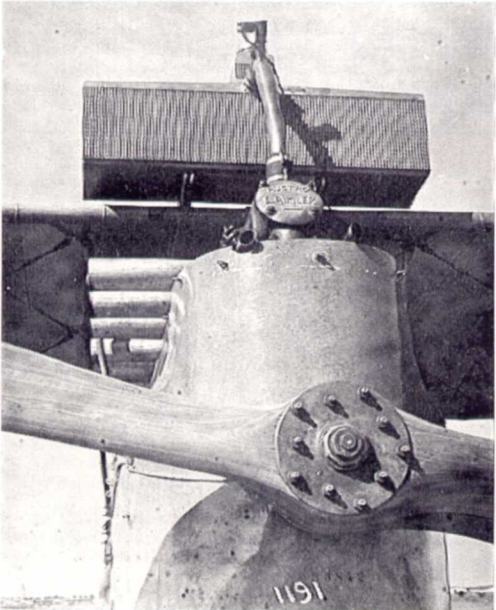

▲57

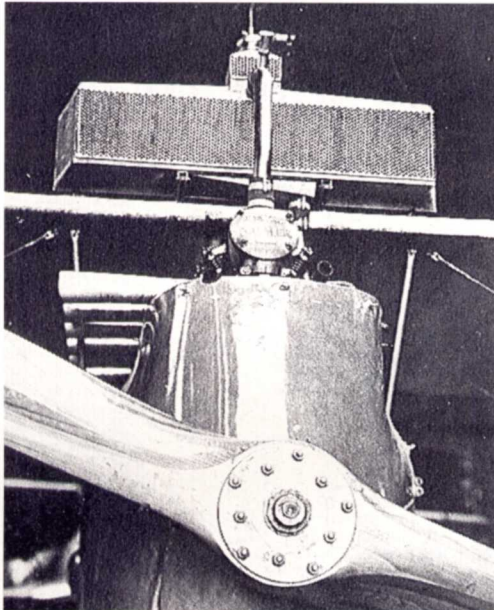

▲58

▼59

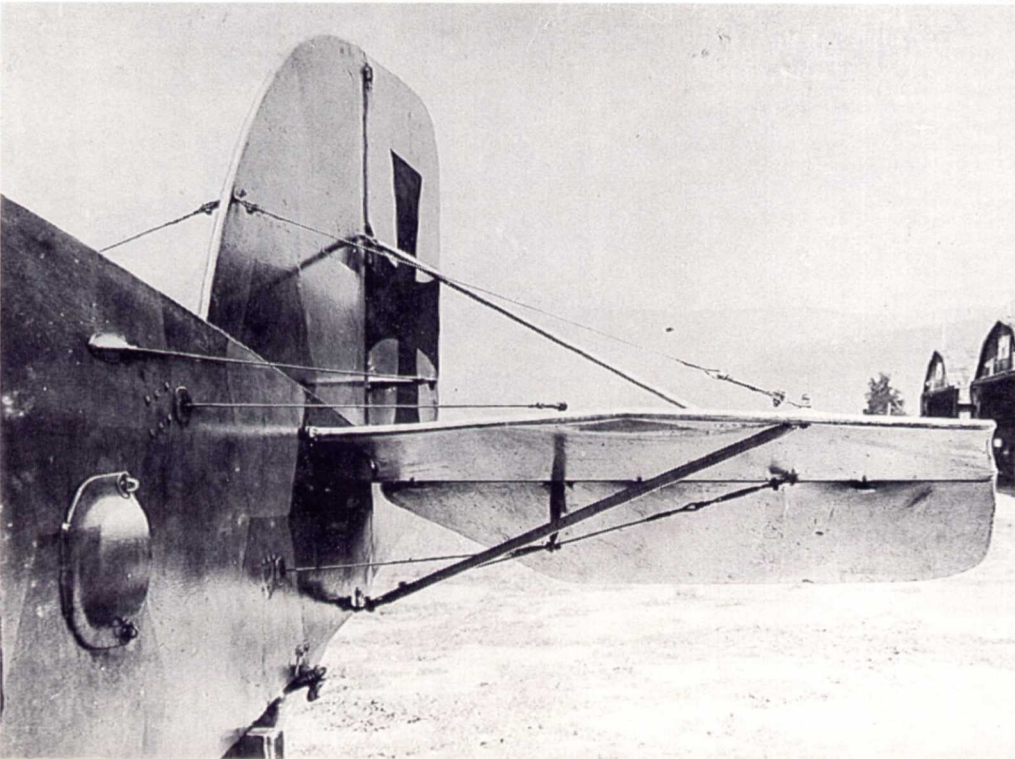

55. Twin side radiators mounted ahead of the centre-section struts on Aviatik D.I 338.23. Although side radiators were tested in several series 338 aircraft, it appears the leading-edge wing radiator became standard on all production machines.

56. Production side radiator mounted on Aviatik D.I 238.41. The aircraft number stencilled on cowl and struts was mandatory.

57. Aviatik D.I 338.42 fitted with a block radiator mounted over the leading edge. The gun barrels are visible just above the engine cowling.

58. Another style of block radiator, seen on Aviatik D.I 338.44, is an indication that several manufacturers supplied radiators, or that the final design had not been chosen.

59. The rather fragile nature of the single-tube framework, damaged during ground handling, is evident in this photograph of an Aviatik D.I.

60. Aviatik D.I 138.27 flown by *Korporal* Andreas Kulscar of *Flik* 4/J as salvaged by an RFC collection unit.

According to a private report pilot Bush, flight leader of No. 45 Sqdn., was attacking a Brandenburg when a Berg fighter appeared. Williams, also of No. 45 Sqdn., attacked him head on and damaged the lower wing spar. The Berg pilot raised his hands and Williams directed him to fly to the other side of the river. At which time Bush turned up and put one bullet in the rear fuselage. Bush claimed the Berg to which Williams would not agree. The two pilots decided to toss for it which Bush won.



▲60

AN EVALUATION OF AVIATIK D.I 138.27 BROUGHT DOWN ON FEBRUARY 2 1918

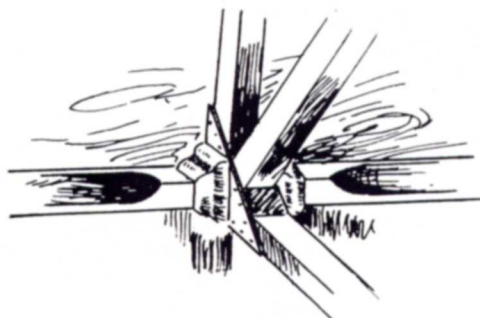

Fig. 1
Strut attachment to longerons.

As a type the Austrian Berg belongs to the single-seater fighter class with high-power engine.

It follows what has now become almost standard practice for single-seaters in its strut arrangement, which comprises only one pair of interplane struts on each side. As a single-seater it is desirable that the view forward and upward shall be as good as possible, and this has been aimed at, and attained to quite a fair extent, in the Berg by placing the top plane low over the body, where, owing to the angle of incidence, the pilot from where he is placed sees it practically edge on. When we say that the top plane has been placed low over the body we do not mean to infer that the gap between the planes has been reduced beyond normal. Rather has the relative position of top plane and top of body been attained by making the body very deep at this point, and by so seating the pilot fairly high in the body — that he obtains the view desired. This is accomplished, not so much by making the main body very deep, but by surmounting it with a fairing or turtle-back of much greater depth than those usually found on machines of this size. With the object always in view of obstructing the pilot's vision to as small extent as possible, this turtle-back, also that portion of it lying in front of the pilot, has been kept narrow at the top. In section it forms what is roughly the shape of a man's head and shoulders, as will be seen from the front elevation in the general arrangement drawings. In this manner, by leaning his head slightly to one side or the other, the pilot can easily see past his engine, the cowling of which, although not in place on the machine examined, has probably conformed to the same contour as the rest of the fuselage top. To the rear of the pilot's seat this turtleback tapers off until it ends in a point some little distance ahead of the tailplane. The lateral taper of it is somewhat more abrupt than is that of the body rails, so that as the rear portion of the body is approached there is a widening strip of flat horizontal surface on each side of the turtleback.

Fuselage

Constructionally the fuselage of the Berg biplane is of the same type as that of the earlier models of Albatros biplanes, *i.e.* there is a light internal framework of wood, covered on sides as well as top and bottom with three-ply. There are no internal wires for bracing the body, the three-ply covering being relied upon to perform this function. Although not possessing such refinements as rounded sides, the body of the Berg is of fairly good streamline form, as will be seen from the illustrations.

It will be seen that there are only four main longerons, whereas the early type Albatros had six, two of which were placed approximately halfway up between upper and lower corner rails. In the front portion of the body the bulkheads are of special form to provide supports for the two engine-bearers. As none of these cradles had been sectioned up on the machine examined, it has not been possible to do more than give their outward shape. Judging from such external evidence, however, as rows of tacks, it appears that these cradles or bulkheads are built up of an internal framework of

spruce, leaving plenty of open spaces, the whole being covered on both sides by thin layers of three-ply wood.

From behind the pilot's cockpit to the stern the main members of the body are of simpler form, simple frames of vertical and horizontal struts alternating with bays in which the rectangular strut frame is reinforced by diagonal struts crossing from corner to corner of the fuselage.

The manner of joining the struts and cross members to the main longerons of the Berg is of the simplest, there being no wire bracing to provide form, with consequent complexity. The struts simply rest, as shown in Fig. 1, on the longerons, and are secured in place by wood blocks. For the quite plain frames the wood blocks are the only supports for the struts, while where the frame is reinforced by diagonal struts — in the manner referred to above — the joint is slightly more complicated as shown in Fig. 1. Here the angles between the vertical and diagonal struts are filled with wood blocks, while a small triangle of three-ply is tacked to the sides, binding the three struts together. In the neighbourhood of the tailskid some slight variations dictated by local considerations are to be found, but the joint shown is typical of the fundamental principle.

The three-ply covering is in the form of fairly large sheets, the use of these being rendered possible by keeping the sides of the body quite flat. Adjoining sheets are butt-jointed, the joint being covered on the inside with a narrow strip of three-ply, which is riveted to the two sheets, thus holding them together. The whole appears to be done in the simplest possible manner so as to facilitate construction, yet it would appear to work quite well in practice. Altogether the impression an inspection of the Berg leaves is to the effect that everything has been designed to meet the requirements of easy production, everything being kept as simple as possible to this end. This does not mean that the workmanship is inferior. As a matter of fact, the workmanship is very good generally speaking, although the finish may be here and there of a slightly less polished order than is found in some machines. The flat top of the fuselage is covered underneath the turtleback by a thin layer of three-ply wood, extensively fretted. The turtleback itself is also of thin three-ply, mounted on light frames built up of several laminations bent to the curvature of the turtleback at any point and glued together. The front faces of these frames are covered with thin sheets of three-ply to prevent bending. Where it joins the flat top of the fuselage the turtleback is tacked to thin strips of spruce, which are in turn tacked and glued to the flat top of the body.

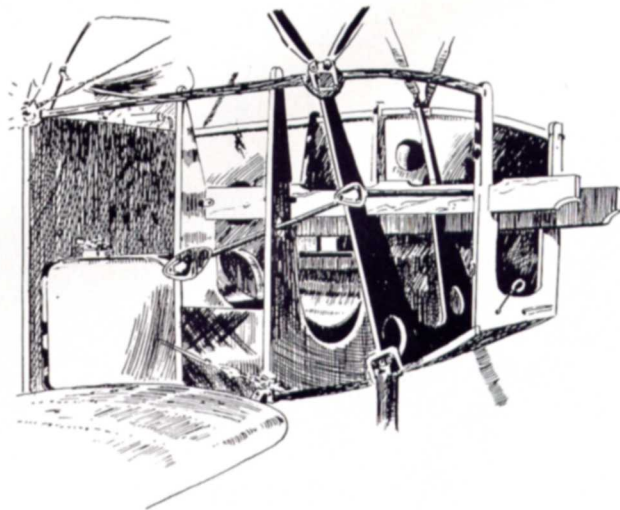

Fig. 2 Engine mounting.

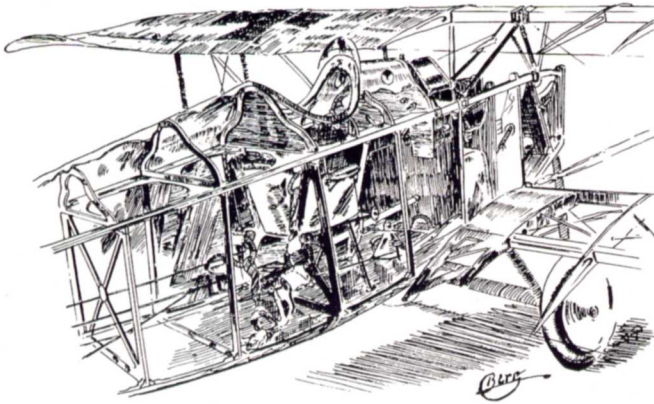

Fig.3 Airframe structure

Fig. 2 shows the general arrangement of the engine bearers and the cradles supporting them. The two engine bearers are built up of three laminations each, all of spruce. As the cradles are not so arranged as to form a series of triangles when seen in side elevations, as is not infrequently done on German machines, the diagonal bracing formed by the 3-ply covering has been reinforced, in the Berg, by two steel tubes on each side. These will be seen in Fig. 2. The front one runs from the point where the engine bearer rests on the front bulkhead to the 3-ply side where this joins former No. 2, the tube being horizontal in side view but sloping out in plan. The second tube, bolted at its front end to the second former, runs through an opening in the third and to the outer edge of the fourth former.

Tanks

The main petrol tank is placed in the bottom of the fuselage, and has, according to a stamp on it, a capacity of 82 litres (about 18 gals.). A small service tank is mounted inside the top cowling of the body, supported on four small steel tubes from the top longerons. This tank has a capacity of 16 litres (about 3.5 gals.). As the various connections are not intact on the machine it has been difficult to follow in detail the petrol feed system, but it appears probable that the main petrol tank is under pressure, the fuel being forced from it up into the small service tank by a hand pump mounted on the port side in the pilot's cockpit.

Instruments

Fig. 3 shows, in perspective, the whole front portion of the Berg. Underneath the turtleback, which has been shown broken, will be seen, in front of the windscreen, the instrument board. Few of the instruments were in place when we examined the machine, and there were no indications that the set of instruments fitted contained any of unusual interest. The sides of the turtle-back are fitted at this point with circular windows in order to provide better lighting of the instrument board.

The pilot's cockpit is of a fairly roomy proportions, and the seat itself is of the 'bucket' type, fitted with comfortable arm rests, which would appear to be a considerable advantage on a long flight. The seat is mounted, as indicated in Fig. 3, partly on the built-up transverse framework at this point and partly on a tubular structure which supports the front of the seat. A safety belt is provided, the springs of which are in the form of rings made up of two sets of coil springs, one inside the other.

Controls

The controls of the Berg are shown in Fig. 4. The control lever itself is somewhat incomplete on the machine, the handle in which it terminates at the top being absent so that it has not been possible to ascertain the shape of the grip, otherwise the controls are intact. The control column, it will be seen, is a steel tube, forked at its lower end, the arms of the fork passing on each side of the longitudinal tubular rocking shaft. From upper and lower ends respectively of this fork pass the top and bottom cables of the elevator controls. A transverse bolt forms the pivot around which the control lever oscillates in a fore and aft direction. The longitudinal rocking shaft is carried in two

bearings, the front one mounted on the bulkhead in front of the pilot, and the rear one carried on two short tubes sloping up from the floor of the cockpit. The aileron control cables are attached to a crank passing down the fore end of the rocking shaft. The effect of this arrangement is that the positive cable — that is to say, the cable that passes from the controls to the aileron-raises an aileron, while the return cable lowers an aileron. Why this arrangement has been adopted is not clear, unless it is assumed that the upturned tip of the ailerons has the effect of putting one aileron under a negative load before the corresponding aileron on the other side begins to exert a positive lift.

The rudder bar of the Berg is welded of sheet steel. It is of T shape as shown in the sketch, the control cables passing from the base of the T instead of from the ends of the main cross bar. The foot bar is mounted on a cone of sheet steel, and is prevented from oscillating by a guide on each side, mounted on two short lengths of steel tubing. The base plate of the rudder bar has at its rear a lug, to which is attached a short length of cable that is bolted at its other end to the lower end of the control column. This cable has the effect of limiting the amount the control lever can be pushed forward, and has probably been incorporated in order to prevent the elevators from hanging down too low when the machine is on the ground. The rudder cables, after leaving the foot bar, pass over pulleys near the floor, on the sides of the body. These pulleys are indicated in Fig. 4, and one of them is shown in detail in Fig. 5. The pulleys are carried on simple sheet steel brackets bolted to a

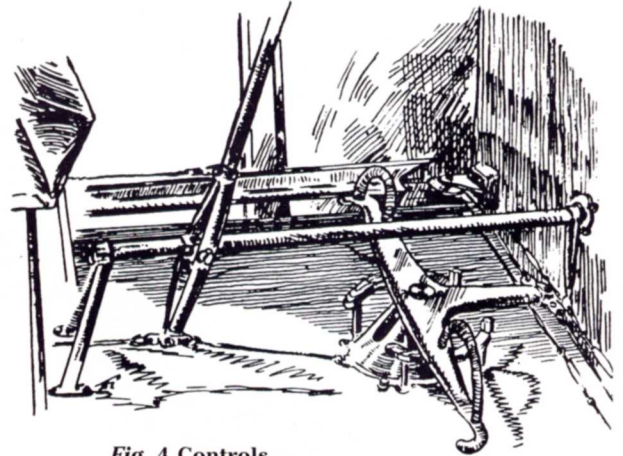

Fig. 4 Controls

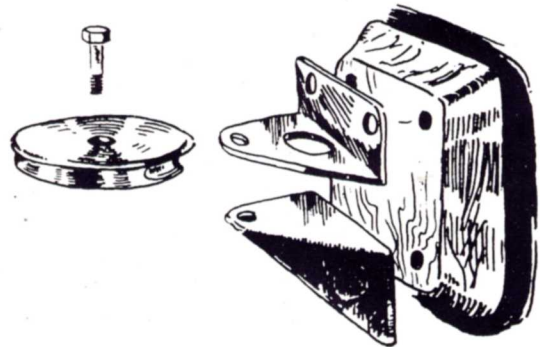
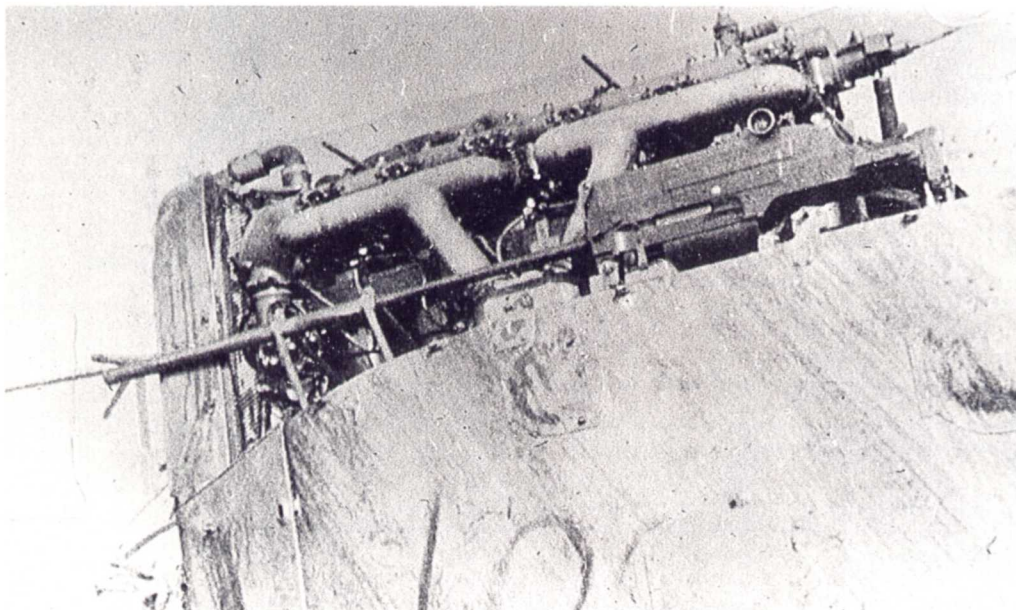

Fig. 5 Rudder cable pulley detail

▼61



61. Captured Aviatik D.I 138.27 showing the position of the Schwarzlose machine gun astride the engine. In this position, the pilot was helpless in case of a gun jam. The official RFC 'Report on 'Berg Scout' Brought Down On The Italian Front' simply states that, 'the fuselage and top surfaces of the planes are camouflaged with a mixture of yellow and green in streaks giving a sandstone effect.'

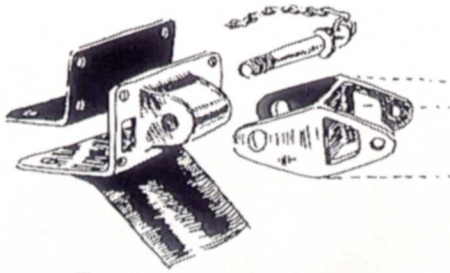

Fig. 12 Attachment of lower rear spar to fuselage.

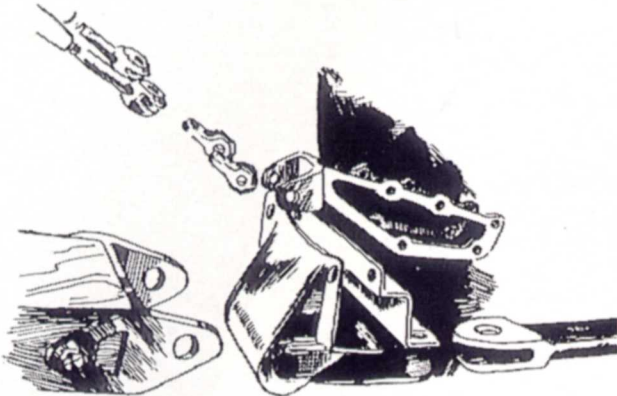

Fig. 13 Attachment of front lower spar and lift cable to fuselage.

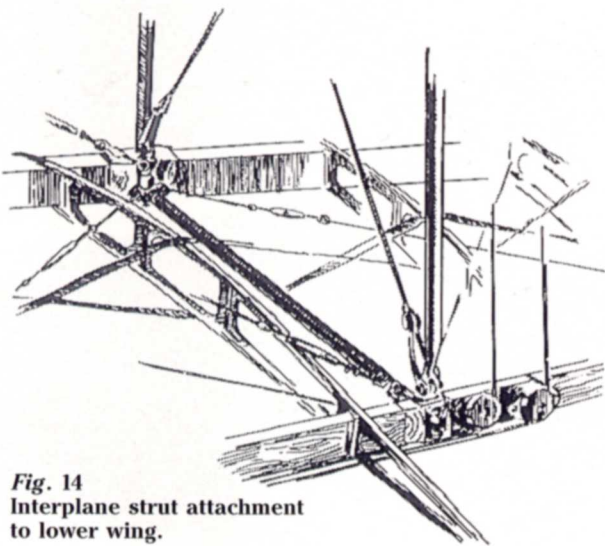

Fig. 14 Interplane strut attachment to lower wing.

Constructionally, the wings are built up of spruce spars of the box type, with ribs having spruce flanges and poplar webs. The webs are fretsawed for lightness, and the solid portions between lightening holes are reinforced by vertical pieces of wood, riveted through the webs. The leading edge is also of spruce, hollowed out to a U section. The trailing edge is in the form of a wire. Between the spars there is a zig-zag formation of tape, passing over one rib and under the next and so on.

The top plane, which is one piece and has no dihedral angle, is supported from the body by N struts sloping outward slightly, as shown in the scale drawings. These struts are streamline tubes, and are pin-jointed so as to allow of adjustment when rigging. The fore and aft adjustment which also serves to bring the wings at right angles to the centre line of the body — is carried out by having portions of the diagonal struts provided with a thread-and-locknut arrangement. The lateral adjustment is carried out in a similar manner. The centre section struts form a letter W, as seen in front view, and the inner legs are provided with the same form of adjustment as are the diagonal side struts. In the rear bay the lateral bracing is in the form of cables, crossing above the body, since these are out of the way of the engine. By using struts in the front bay and placing them in a W formation the difficulty of clearing the engine is overcome, and adjustment still rendered possible. Fig. 10 shows the attachment of the front and diagonal side struts to the top longeron. The struts have forked ends, which fit over the vertical lugs of the base plate that rests on and is bolted to the longeron. Directly bolted to the inner part of this base plate is the foot of the strut that provides lateral bracing for the front bay. This strut is rigidly attached to the longeron, but has the thread-and-locknut adjustment at its upper end. The attachment of the rear side strut is shown in Fig. 11. This is similar to the attachment of the front struts, but there is the difference caused by the fact that in this bay the lateral bracing is in the form of cables. The manner in which this cable is attached to the base plate is shown in the sketch.

The attachment of the lower planes to the fuselage is shown in Figs. 12 and 13. The rear spar attachment is shown in Fig. 12. To the outer base plate is welded the lug to which the spar is attached by a forked spar box and a quick-release bolt. The rear strut of the undercarriage is also welded to this base plate, but the lower horizontal is part of it.

Fig. 13 shows the attachment of the lower front spar and of the lift cables. The spar attachment is, it will be seen, very similar to that of the rear spar. There is, however, a horizontal tube running across the fuselage, thus resisting any tension there may be on the spars, while the lift cable attachment is also extended some distance in the manner shown, so as to spread the load to other of the members of which the bulkhead is composed.

The fittings for the internal bracing of the planes are of a very neat and simple type. The compression struts are in the form of steel tubes, and the drift bracing is stranded cables, while the anti-drift wires are of the solid type. The interplane struts are stream-line steel tubes, forked at their ends and fitting over eyebolts passing vertically through the spars. The general arrangement of these attachments and of the internal bracing system are indicated in Fig. 14. An analytical sketch of the fitting is given in Fig. 15. It consists of two forgings, one placed on top of the spar and one on the lower side of the spar, the two being held together by vertical bolts passing on the outside of the spar. In addition there is an eyebolt going through the spar, and to this is anchored the forked end of the interplane strut. The left cable is attached by means of a shackle to a lug formed on the top forging. The incidence cable is attached to the horizontal bolt passing through the fork end of the strut and through the eyebolt, by two very long chain links as shown. The compression tube between the wing spars also occurs at this point, and is attached to one of the vertical bolts on the side of the spars. This is done by welding to the end of the compression tube a strip of sheet steel forming the lugs of the internal bracing, and through the solid part of metal thus formed bore a hole for the vertical bolt. The whole joint is very neat when in place, and is shown from the outside in Fig. 16. This sketch also shows the mounting, on the lower spar, of the aileron cable pulleys.

We have referred to the aileron control system, in which the direct cable from the controls passes to the forward arm of the aileron crank lever, thus pulling the aileron up, while the pulling down of the opposite aileron is left to the return cable. It was pointed out that this system, which is rather the reverse of what is usual practice, has probably been adopted because of the warped ailerons,

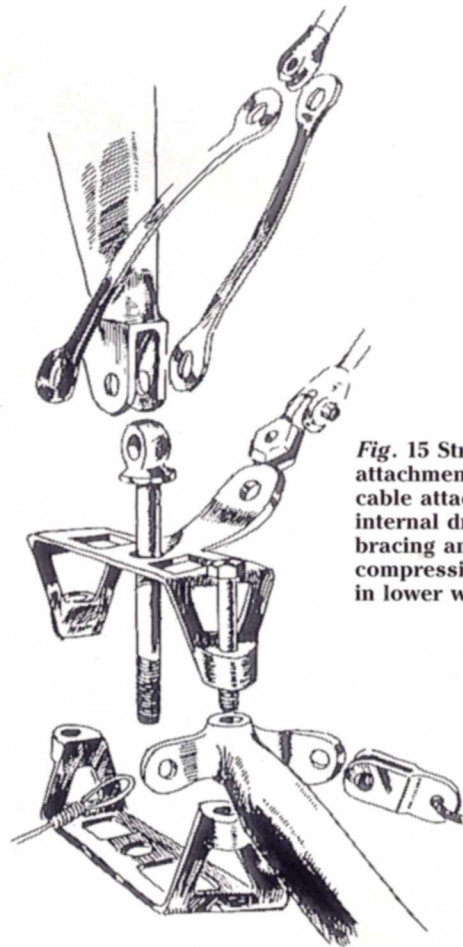

Fig. 15 Strut attachment, lift cable attachment, internal drift bracing and compression tube in lower wing.

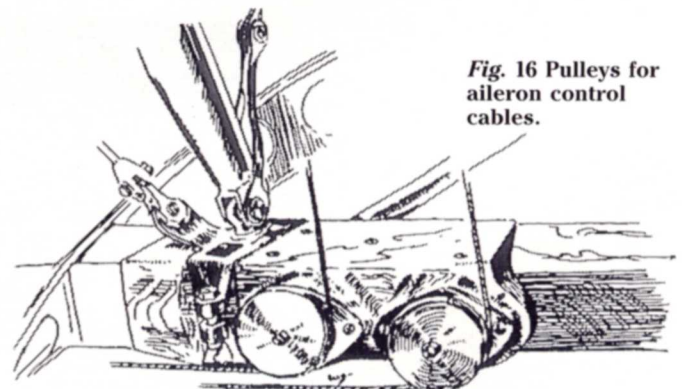

Fig. 16 Pulleys for aileron control cables.



62. The open door shows the location of the remotely-controlled camera as installed in the Aviatik D.I photo-reconnaissance fighter. The guns have padded butts to protect the pilot. The pilot, *Oblt. Ludwig Stilmungus*, CO of *Flik 40/P* was killed in combat on August 12 1918.

▲62

Fig. 17 Top wing.

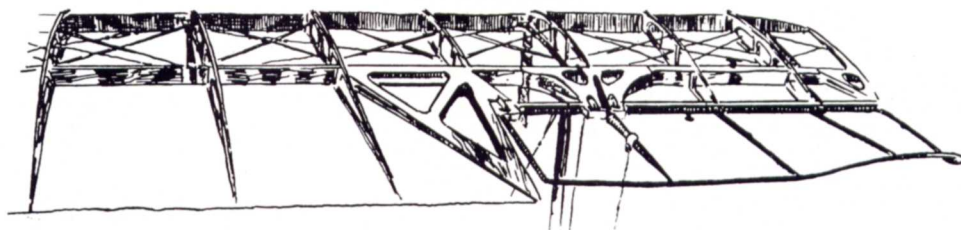

which may possibly owing to their upward turned tips come under a negative load before the opposite aileron begins to give a positive lift. The aileron and a portion of the upper plane are shown in Fig.17. The aileron, which is of tubular construction, is hinged to a false spar as in nearly all machines of enemy origin. It will be noticed that this portion of the top plane is generously provided with three-ply reinforcement. The horizontal aileron crank lever works in a slot formed by triangles of ply-wood, and the control cables pass from the cranks over pulleys as shown in Fig. 16, and hence to the controls, passing through the bottom plane.

Camouflage

The Berg single-seater is somewhat different from German machines in its camouflage, possibly because it had been used on the Italian front, where the ground is of different colouring. The whole of the tail and the undersurface of both mainplanes are painted a pale sandy yellowish brown, while the body and top surfaces of the planes are painted in addition with irregular streaks of a darker brown. N.B. The above is an excerpt from *Flight and The Aircraft Engineer*, October/November 1918 based on evaluation of D.I 138.27 brought down on February 2 1918, capture No. AG.6; see photos 60 and 61 on pages 28 and 29. □

COLOURS AND MARKINGS compiled by R L Rimell

The subject of colours and markings applicable to the Aviatik D.I fighters is an extraordinarily complex and lengthy one and has already formed the basis for a detailed discourse in the late Dr. Martin O'Connor's series in various 1986 issues of the *Cross and Cockade Great Britain Journal* as well as coverage in *Scale Models* and recent books. The bibliography at the end of this section will direct the reader to as much data as he is ever likely to need on the various D.I colour schemes and national, unit and personal insignia pertinent to the type. Space precludes all but the briefest of overviews in this book and we are indebted to Dr. O'Connor's lengthy and patient researches which have enabled us to provide the bare notes which follow. . .

A) Plain

Wood areas were clear varnished and all fabric-covered surfaces clear-doped; metal panels around the nose, inspection plates and struts were normally painted a blue/grey (Methuen 23D2). Only a few early D.Is were thus finished and many were subsequently camouflaged in the field by green mottling or splotching over the upper surfaces.

B) Factory schemes

At least three versions of a factory-designed and applied pattern have been identified.

1) 'Autumn Leaf'

Three colours applied by rag or sponge were applied to all upper surfaces. An elevator of a D.I preserved in Milan's Leonardo da Vinci Museum of Science and Technology is a good example of this pattern, *viz*: three colours applied by sponge in the following order: dull yellow (Methuen 4B6) red-brown (7D7); and medium green (27E8) — other variations in colour have been recorded but generally the lighter colour was applied first. In general machines so finished featured the blue/grey metal panels and struts but on occasion these areas also were camouflaged.

2) Streaky

This application, similar in style to Fokker-built types such as the D.V and DR.I, was used during Winter 1917/18 and consisted of a light overall colour over which a darker paint was streaked on all upper and side surfaces — usually at 45% on wings and horizontal tail surfaces and vertically on fuselage, fin and rudder. The *Flight* report (see pages 28-32) details this form of scheme on captured D.I

138.27. Fabric from this machine survives in the IWM and reveals the base colour as a light tan (5C4) with streaky application of a dark brown (6E7) over it.

3) 'Transition'

This combines the features of both the above patterns where aeroplanes could be seen painted in splotches and oblique streaks.

C) 'Lozenge' camouflage

From Spring 1918 onwards the Aviatik D.I began to appear in a camouflage consisting of hand-painted hexagons in various colours grouped usually into groups of 'light' and 'dark'-coloured hexagons 3-7 hexagons wide. The pattern was commonly applied to upper and side surfaces but rarely on lower surfaces.

Few examples of this pattern have survived. For many years the National Technical Museum's Knoller C.II (Lo) 119:15 (in Prague, Czechoslovakia) bore the only genuine source of reference to these colours (see *WS* Vol.8, No.2) and its pattern and colour distribution was noted by several historians (see **Table 1**) before it was recovered and repainted — incorrectly!

As far as the D.I was concerned, the pattern was adopted by four manufacturers of the type: Aviatik, Lohner, WFK and Thöne & Fiala all of whose applications varied. For a detailed breakdown of these patterns one is referred to pages 122-127 of *Cross and Cockade International* Vol.17, No.3 (1986), but briefly the main variations of the four manufacturers was as follows: *Aviatik* — hexagons were equilateral and on fuselage, fin and rudder applied vertically (points up and down) or horizontally (on their flats). On wings and tailplanes the hexagons were painted with their flats or points facing leading and trailing edges.

Lohner — two forms of hexagons; in equilateral form applied vertically on fuselage, fin and rudder with points facing trailing and leading edges of wings and tailplane. Another pattern consisted of small, rectangular hexagons painted horizontally on fuselage, fin and rudder, the points facing fore and aft on the wings and tailplane.

WFK — hexagons applied at this factory were large and slightly rectangular. On the fuselage the hexagons were painted obliquely from top fore to bottom aft — a trait peculiar to WFK — while the points faced leading and trailing edges of wings.



63. Aviatik D.I 38.04, an early production machine, was recorded as serving with *Flik* 4/D (November 1917), *Flik* 42/J (January 1918) and lastly with *Flik* 68/J. It was written off in July 1918.

Thöne & Fiala — equilateral 'lozenges' were applied vertically to fuselage, fin and rudder. On wings and tailplanes the flats or points could face fore and aft.

D) Serrated bands

In this pattern the top and side surfaces of the fuselage, wings and tail were painted with oblique bands of light and dark colour with a distinctive 'sawtooth' margin that suggests a simplified version of the hexagonal patterns since the demarcation of the two colours appears to match the interfaces of the light and dark 'lozenge' groups. It must have speeded up the finishing of machines in the factory paint shops and saved considerably on coloured dope stocks.

Vienna's surviving D.I (Th) 101.37 (see colour photos in *WINDSOCK* Vol.10, No.3 published coincidentally with this *DATAFILE*) is painted in the serrated scheme. The colours are tan (4C6) and dark green (28F6). Metal nose panels and struts are the usual blue/grey.

This pattern began to appear on the the D.I during the last Summer of the war and while usually applied by hand providing a hard demarcation between the colours, some Lohner-built examples of the 315 series must have had this pattern sprayed as the interfaces were soft.

E) Wavy bands

Aviatik, Lloyd and MAG-built D.Is in late 1918 adopted variations of the 'serrated' scheme. The demarcations of the two colours (the same shades as quoted above) were now wavy but varied among the manufacturers depending on

methods of application. On MAG-built D.Is the demarcations are sharp, but in the later series 338 machines of Aviatik the demarcations are less well defined, the colours probably applied by saturated rag. Series 348 Aviatiks built by Lloyd have quite soft demarcations and here it is thought the paint was applied by splotching with heavily-soaked sponges.

KEY TO REAR COVER COLOUR PLATES

1) Aviatik D.I 38.02, May, 1917.

This machine displays the typical scheme of early Aviatik D.I fighters in the first 15-20 series 38 machines. As delivered the machine has its wood fuselage clear varnished, with the wings, tailplane/elevators, fin, rudder and wheel covers covered in plain linen and clear doped. The upper surfaces of wings and tailplane were probably later painted in the 'Autumn Leaf' scheme as 38.29 — colour plate 2. The early style national markings are painted in plain black on the upper surfaces of the upper wing and under the lower wings. Nose panels and all struts are painted in the blue/grey colour commonly used by Aviatik. Rudder is a solid colour, depicted here as red/brown.

Source, *photograph 1*, on the inside front cover.

2) Aviatik D.I 38.29 flown by *Zugsführer* F Körty-Lalitz of *Flik 17/D*, 1918.

All upper surfaces are painted in mottle camouflage of yellow ochre, red/brown and dark green applied over wood and fabric areas by saturated rag or sponge. The rudder is painted a solid colour which is shown green here but this is speculative. Wheel covers and



▲64 ▼65

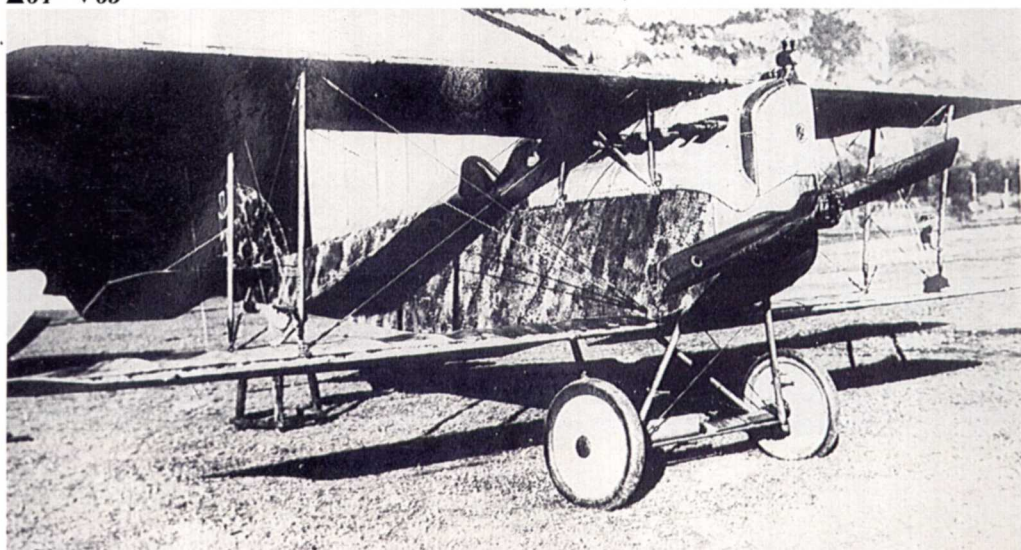

64. Aviatik D.I 38.29 was dispatched to the Front in March 1918 armed with an over-the-wing gun. The deep cockpit is noteworthy. It was flown by *Zugsführer* Körty-Lalitz of *Flik 17/D* — see colour plate 2.

65. An unidentified Aviatik D.I on the Italian Front. The modern airscrew was the result of an aggressive research programme including testing in a modern wind tunnel. As a result, Austria-Hungary was a leader in World War One airscrew design.

under surfaces of wings and tailplane are clear-doped, the metal nose panels and struts in blue/grey. The national insignia on upper wing upper surfaces and the rudder are white outlined but those below lower wings are painted on white squares, a practice begun in Italy during September 1917.

Source: *photograph 64*, page 34.

3) Aviatik D.I 38.58, Wiener-Neustadt, Autumn 1918.

This machine is finished in the serrated band camouflage scheme of tan and dark green bands 'stepped' in the manner of the 'lozenge' colour band groupings. Wheel covers and undersurfaces are clear-doped and the fin is painted an unknown solid shade shown on the plate as blue. The colour of the fuselage band is equally elusive and is depicted red in our reconstruction. National insignia on upper wing upper surfaces and rudder are white outlined.

Sources: *photograph 66*, page 35.

Recommended references

For full Aviatik D.I colour scheme data the following references are firmly recommended: 'Markings and Camouflage of Austro-Hungarian Aircraft in World War I' by Dr. Martin O'Connor. Part I, published in *Cross and Cockade Great Britain Journal*, Volume 17 No.1, 1986, provides a general introduction which specifies and illustrates national insignia styles and changes; serial and stencil data. Also features six colour plates showing D.I camouflage variations. Volume 17, No.2 includes the first of a detailed two part discourse on D.I colours — concluded in Vol.17, No.3. Part I provides detailed descriptive notes, Methuen codes and reference photos, part 2 details the various painted hexagon schemes with colour references and a number of drawings showing the various patterns, orientation to airframes, colour groupings, etc.

Air Aces of the Austro-Hungarian Empire 1914-1918 by Dr. Martin O'Connor, published by *Champlin Fighter Museum Press* in 1986 and due to be reprinted. Details the aces of the Dual

▼66

Monarchy and includes four colour plates of D.I fighters by R L Rimell.

Austro Hungarian Army Aircraft of World War One by P M Grosz, G Haddow and P Schiemer, *Flying Machines Press* — colour notes by Dr. O O'Connor and five colour plates of D.I fighters by A Durkota.

Acknowledgements

The author and publishers acknowledge the researches of the late Dr. Martin O'Connor in respect of Austro-Hungarian colours and markings on which the foregoing text has been based. □

Hexagonal camouflage colours and patterns

In 1959 Pavel Vancura and Peter Gray made a detailed study of the Lohner-built Knoller C.II in Czechoslovakia's Technical Museum in Prague. The results of their observations were first published in the *June* 1959 issue of *AeroModeller* and is excerpted below. Their findings, based on direct observation and measurement, are just as valid now as they were 35 years ago especially since the C.II no longer wears its original fabric. . .

'The hexagons on the fuselage are painted on, no less than nine shades being used in the pattern from the nose to the rear cockpit, aft of this a "repeat" pattern of only three shades is used. It is to be noted that the wing pattern has a five-shade combination of colours whereas the tail plane pattern has only four shades (see Table 1).

'The undersurfaces of the wings and tailplane are clear doped natural linen fabric, ie., a creamy beige shade and the bottom surface of the fuselage is pale blue. All struts are dark green including undercarriage. The radiator is natural brass and the water pipe to the engine is painted blue.'

It should be noted that these colours and patterns are applicable to one machine only and may have differed from those used on the Aviatik D.I fighters. However, it does at least provide one accurate source for this unique and unusual camouflage practice. □

66. Aviatik D.I 38.58 fitted with side radiators and cowl-mounted guns served with *Flik 56/J* before joining the Wiener-Neustadt defence flight in Autumn 1918. An identification pennon flutters on the outer wing strut — see colour plate 3.



Table 1 – Hexagonal pattern.

FUSELAGE COLOURS.

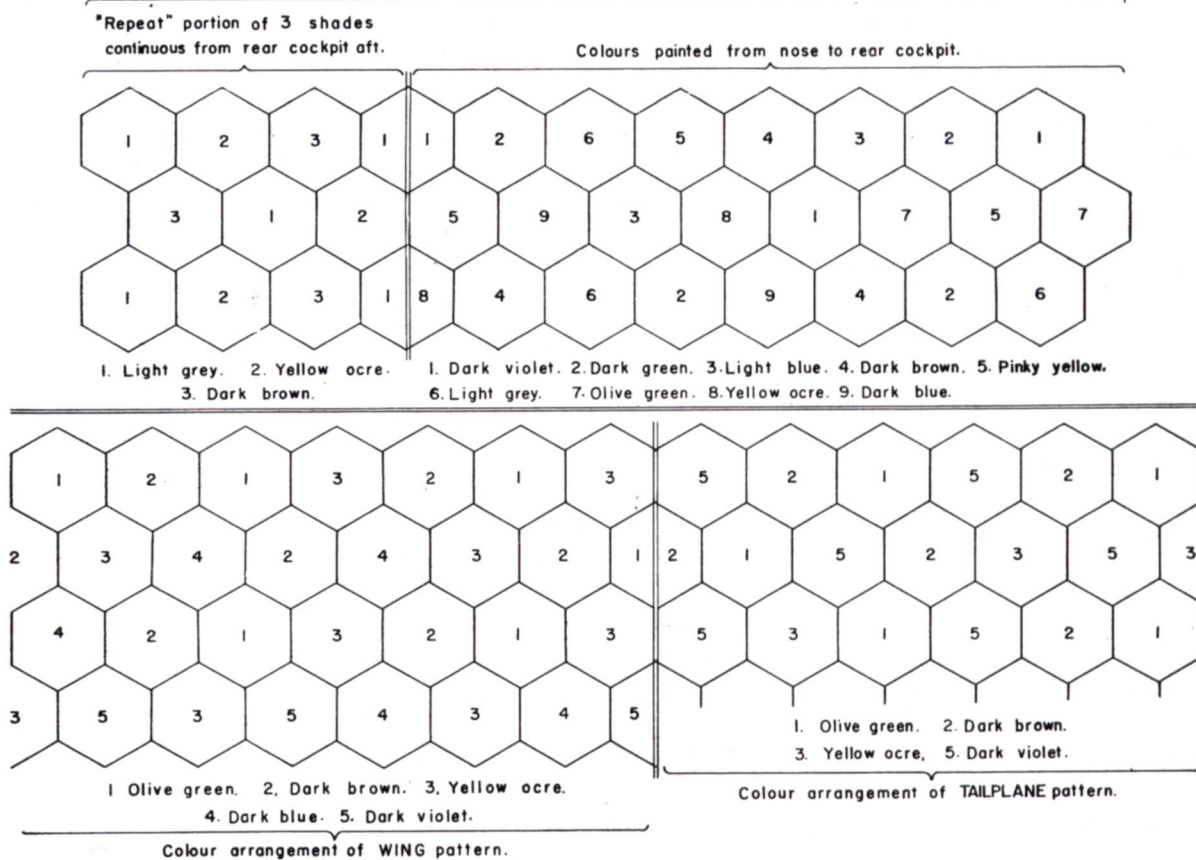

Table 2 – Colour notations

Colour name	Methuen Ref	Humbrol Mix	Application
Prussian Blue Dark Maroon	21F6 9F6	15/G 13 Midnight Blue 3 parts HN5 Hull Red + 1 part HB10 Black	Six colour hexagonal camouflage for uppersurfaces.
Dark Sage Mauve	29F3 15E4	HG2 Dunkelgrün 72 2 parts N9 Mauve + 2 parts HB10 Black	
Ultramarine Brown Ochre	21C5 6E5	Matt Blue 25/M27 HB2 Dark Earth	
Light Blue Pale Violet Light Green	25B5 14B4 28C3	Equal parts 3/G5 Brunswick Green + HB6 Sea Grey Medium + dash 14/G6 French Blue 20 Crimson + 22/G3 Gloss White 2 parts MC28 Green Leather + 1 part 69/G2 Yellow	
Ochre Pink Grey Blue Grey	4B3 9B2 26B3	62/M23 Leather + dash 7 Light Buff HB6 Sea Grey Medium + dash 19/G11 Crimson 3/G5 Brunswick Green + HB5 Sky	Undersurfaces
Clear doped Linen	4A3	HN4 Deck Bleached Teak	

N.B. These colours as applied to the Aviatik D.I were researched by Ian D Huntley of **Aerocam** and offer yet further variations of the colours used on WWI Austro-Hungarian machines.

AVIATIK D.I SURVIVORS

AUSTRIA (1)

Technisches Museum Fur Industrie und Gewerbe, Mariahilfer Strasse 212, 1140 Wien.

Aviatik D.I 101.37 displayed with starboard fuselage and upper wing uncovered. See colour close-ups in *WINDSOCK International*, Volume 10, No.3, May/June 1993.

USA (1)

Champlin Fighter Museum, 4636 Fighter Aces Drive, Mesa Arizona, 85205.

Aviatik D.I 101.40 restored in authentic 'Autumn leaf' scheme – see also *WWI Survivors* by R L Rimell, Aston Publications, Ltd., 1990.

APPENDICES

BIBLIOGRAPHY

Biedermann, Herbert. *Die Aviatik - eine Döblinger Flugzeugfabrik*, Döblinger Museumsblätter, Nr.70/71, 1982.

Grosz, Peter M., George Haddow and Peter Schiemer, Aviatik D.I, Austria-Hungary's first indigenous fighter, *Air Enthusiast Quarterly*, No.21, 1983.

Grosz, Peter M., George Haddow and Peter Schiemer, *Austro-Hungarian Army Aircraft of World War One*, Flying Machines Press, 1993.

Haddow, George. *The O.Aviatik (Berg) D.I*, Profile Publications No.151.

Notes on the Austro-Daimler Engine in Austrian Berg (A.G. 6), Headquarters, Royal Flying Corps, March 8 1918.

Report of Armament of "Berg" shot down by Captain W.G. Barker, DSO, MC, No.66 Sqdn. RAF on May 21 1918 north of Treviso. In the Field, May 26 1918.

Report on "Berg" Scout Brought Down on the Italian Front, Headquarters, Royal Flying Corps, March 8 1918.

Taylor, John W.R., The Ö Aviatik "Berg" D.I, *Model Aircraft*, May 1963.

The Austrian Berg D.I Single-Seater, 200 HP Austro-Daimler Engine, *Flight* October 24 and 31 and November 14 1918. □

CHART OF AVIATIK D.I PRODUCTION ORDERS

Company	Serial numbers	Engine	Quantity ordered	Number at Front 8.18
Aviatik	38.01-38.72	185 Dm	72	35
	138.01-138.64	200 Dm	88	48
	138.97-138.120	200 Dm		
	238.01-238.90	160 Dm	120	89
	238.105-238.134	160 Dm		
	338.01-338.08 338.21-338.120	225 Dm 225 Dm	108	2
Lohner	115.01-115.89	200 Dm	89	59
	315.01-315.76	225 Dm	76	0
Lloyd	48.01-48.10	185 Dm(MAG)	10	0
	248.01-248.20	160 Dm(MAG)	20	0
	348.01-348.70	225 Dm(MAG)	70	0
MAG	92.01-92.172	200 Dm (MAG)	172	28
Th & F	101.01-101.24	200 Dm	51	18
	101.31-101.60	200 Dm		
	201.04-09 (Note 201.01-201.03 became 101.22-24)	185 Dm	9	2
WKF	84.01-10	185 Dm	10	0
	184.01-24	200 Dm	24	1
	284.01-24	160 Dm	24	18
	384.01-40	225 Dm	40	0

DATA

Published by **Albatros Productions, Ltd.**,

10 Long View, Chiltern Park Estate, Berkhamsted, Hertfordshire, HP4 1BY, Great Britain.

Copyright © 1994 Albatros Productions, Ltd.

Printed in Great Britain.

ISBN No. 0 948414 60 X

Exclusive distribution to North American hobby and craft shops, museums and book shops by Bill Dean Books, Ltd., PO Box 69, New York 11357, USA. (Tel: 1-718 359 6969).

Designed, edited and produced by R L Rimell.

Co-publisher: A M Hogan.

Colour profiles by R L Rimell.

Scale drawings by S J Simkin.

Mono origination, printing and binding in Great Britain by The Magazine Printing Company Limited, Enfield, Middlesex, EN3 7NT.

Colour origination by Columbia Offset (UK and Singapore).

The contents of this publication are strictly copyright and may not be reproduced or transmitted in any form whatsoever, either in whole or in part, without the prior, written consent of Albatros Productions, Ltd.

Author's note

The photographs are from the author's collection. To avoid any misunderstanding, the author, P M Grosz, should like to make it absolutely clear that the colours and markings section, as in all *DATAFILES*, is the sole responsibility of editor Ray Rimell and that the author is not involved in producing this material. □

AVIATIK D.I MODEL KITS – compiled by Ray Rimell

Non-flying models	Manufacturer	Country	Date	Scale	Remarks
Aviatik D.I	Sierra Scale Models	USA	1988	1:48	Vacform
Aviatik D.I	C A Atkins	UK	1986	1:72	White metal
Aviatik D.I	Classic-Plane	Germany	1982	1:72	Vacform
Aviatik D.I	ÖFH	Austria	1986	1:72	Resin
Aviatik D.I	Aero 72	UK	1987	1:72	Injection-moulded

NB: Further details of these models appeared in Part 7 of the 'WINDSOCK A-Z of Scale WWI Aeroplanes'; *WS* Volume 8, No.6, Nov/Dec 1992.



1) AVIATIK D.I, 38.02.



2) AVIATIK D.I, 38.29.



3) AVIATIK D.I, 38.58.